

UTAH COUNTY
PUBLIC WORKS DEPARTMENT
2855 South State Street
Provo, Utah 84606
(801) 851-8600

INVITATION TO BID

For

**6400 South Bridge Replacement
– Culvert Purchase
ITB # 2024-9**

CLOSING DATE
FOR RECEIPT OF BIDS:

Wednesday, August 21, 2024

TIME:

3:00 p.m.(Mountain Time)
Bids will be opened at 3:10 p.m.

PLACE:

Office of the Utah County Purchasing Manager
100 East Center Street
Room 3600
Provo, Utah 84606

NOTE: The Contractor is responsible for reading the contents of this bid, including but not limited to, the Scope of Work, General Requirements, Specifications, the Drawings and Agreement. The Contractor is also responsible to visit the work sites before presenting a bid.



TABLE OF CONTENTS

INVITATION TO BID

Intent	1
Procedure	1
Rules of Procurement.....	1
Bid Organization	1
Proprietary Information	3
Questions and Clarifications	3
Acceptance of Bid.....	3
Disqualification of Bid.....	3
Disposition of Bids	4
Interpretation of ITB.....	4
Required Experience.....	4
Evaluation Criteria	4
General.....	5
Bonds	5

GENERAL REQUIREMENTS

Alterations of Plans or Character of Work.....	7
Brand Name	7
Change Order	7
Completion Date	8
Liquidated Damages	8
Cooperation.....	9
Delivery/Shipping.....	9
Extra Work	9
Inspection.....	10
Insurance.....	10
Keys	10
Legal	10
License	10
Payment.....	10
Safety Requirements	11
Sales Tax	12
Supervision of Work	12
Surveying	12
Utilities.....	12

CONTRACTOR’S BID SCHEDULE Attachment A

Specification Measurement and Payment..... Attachment B

Delivery.....	S-1
Culvert.....	S-1
Wingwalls & Parapets.....	S-1

Specifications	Attachment C
Summary of Work	S-2
Product Delivery and Handling	S-3
Pre-Cast Concrete Box and Three-Sided Culvert Structures	S-4
Plans & Drawings	Attachment D
CONTRACTOR INFORMATION FORM.....	Exhibit A
CERTIFICATE OF NON-COLLUSION.....	Exhibit B
SAMPLE AGREEMENT WITH STANDARD TERMS & CONDITIONS.....	Exhibit C

1. INVITATION TO BID

1.1 INTENT

- A. Through this Invitation to Bid (ITB), Utah County intends to select a contractor/supplier to provide a pre-cast 6' x 24' box culvert with headwalls, wing walls, and parapets to be delivered within Utah County as per the specifications, plans and drawings included in or referenced in this ITB.
- B. The Contractor shall furnish all labor, equipment, tools, transportation and supplies required to complete the work in accordance with the specifications, drawings, general requirements and terms of this Agreement.
- C. Pursuant to this ITB an agreement will be executed, a sample copy of which is attached as Exhibit C. **The County will not entertain changes to its Standard Terms and Conditions.**

1.2 PROCEDURE

The procedure for response to this ITB, evaluation of bids, and selection of a Contractor is as follows:

- 1. Interested entities will prepare and submit their bids prior to the specified Closing Date for Receipt of Bids.
- 2. Utah County and/or its representatives will evaluate all submitted bids to determine acceptance or rejection of the bids.
- 3. The selected bidder(s) will be required to sign an agreement, a sample of which is included as Exhibit C.

1.3 RULES OF PROCUREMENT

- A. This procurement shall conform to and is governed by The Utah County Division of Purchasing, Procurement Rules and Regulations.
- B. For this procurement, all bids must be submitted in the bid format outlined herein.
- C. All prospective bidders must meet the required criteria as of the date of submission. Respondents must provide all information requested in the Contractor Information Form.
- D. Utah County has established certain requirements with respect to bids to be submitted by respondents. The use of "shall", "must", or "will", in this ITB indicates a requirement or condition from which a material deviation will not be approved by Utah County.

1.4 BID ORGANIZATION

- A. Each respondent must submit its SEALED bid to the Utah County Purchasing Manager, Robert Baxter. The envelope containing the bid must be clearly labeled "SEALED BID – 6400 South Bridge Replacement – Culvert Purchase, ITB # 2024-

9". The bid must be delivered by mail or hand delivery by **Wednesday, August 21st at 3:00pm** to:

Utah County Purchasing Manager
100 East Center, Room 3600
Provo, Utah 84606

LATE BIDS WILL NOT BE ACCEPTED EXCEPT AS SET FORTH IN UTAH COUNTY PROCUREMENT RULES AND REGULATIONS.

B. Items to be considered before filling out the bid and bidding schedule:

1. Interpretation of Quantities in the Schedule

Any quantities appearing in the Specifications or the Drawings for this project are only approximate and were prepared from estimates by the County Project Manager. These quantities will be used for bidding. The actual quantities for construction may vary and should be determined by the Contractor based on their individual analysis of conditions. In the event certain areas of the project are given a higher priority, those areas, as designated by the County Project Manager, will receive construction attention first. In the event certain areas are deleted due to unforeseen appropriation of funds, or deemed not economically feasible, or for whatever reason, those areas will be deducted from the bid and payment amount.

2. Bidding Schedule

The bidder shall submit the bid upon the bidding schedule and bid sheets provided by Utah County. The total amount of the bid is obtained by adding the "Total Cost" amounts of the several bid items or unit priced items multiplied by the estimated quantities. All the figures shall be in ink or typed. The bid must be signed in ink by the individual who prepared the bid and by the owner of the company. The address and phone number of the individual or firm represented by the bid must be on the bid. The bid process is governed by and subject to the Utah County Procurement Rules and Regulations.

C. The bid must include:

1. Completed Contractor's Cost Proposal (Attachment A)
2. Completed Contractor Information Form (Exhibit A).
3. Completed Certificate of Non-Collusion (Exhibit B).
4. A copy of the bidder's current local business license.
5. A copy of the bidder's current Contractor License issued by the Utah Department of Commerce, Division of Occupational and Professional Licensing.
6. Proof of required insurance.
7. Documentation from the County Treasurer of the bidder's county showing that bidder is current on its personal property taxes.

1.5 PROPRIETARY INFORMATION

The Contractor shall mark proprietary information contained in the bid which is not to be disclosed to the public or used for purposes other than the evaluation of the bids. Pricing and service elements of the successful bid will not be considered proprietary.

1.6 QUESTIONS AND CLARIFICATIONS

A. All questions regarding this ITB must be submitted through the Utah Procurement Place (U3P) web site. The deadline for submission of questions is before 5pm at least two business days prior to the submission date. The County Project Manager for this project is listed below:

County Project Manager Contact	
County Project Manager	Glen Tanner
Office Phone No.	(801) 851-8602
Cell Phone No.	(801) 420-7619
Email Address	gkent@utahcounty.gov

- B. Bidders are urged and expected to inspect the site where services are to be performed and to satisfy themselves as to all general and local conditions that may affect the cost of performance of the Agreement, to the extent such information is reasonably obtainable. In no event will a failure to inspect the site constitute grounds for withdrawal of a bid after opening, or for a claim after award of the agreement.
- C. To arrange to inspect the work site or for other inquiries on this invitation for bids, prospective bidders should contact the “County Project Manager”, using the contact information above.

1.7 ACCEPTANCE OF BID

- A. Utah County reserves the right to reject any or all bids or waive minor irregularities when to do so would be in the best interests of Utah County. Minor irregularities are those which will not have a significant adverse effect on overall competition or performance levels.
- B. The responding party agrees that Utah County may terminate this procurement procedure at any time, and Utah County shall have no liability or responsibility to the responding party for any costs or expenses incurred in connection with this ITB, or such party's response.

1.8 DISQUALIFICATION OF BID

- A. The occurrence of any of the following may result in disqualification of a bid:
 1. Failure to respond within the established timetable.
 2. Failure to completely answer all questions presented in the ITB.
 3. Use of any other type of form or format other than those indicated in the ITB.

4. Failure to provide requested documentation at the time of bid submission.
 5. Illegible responses.
 6. If the bidder adds any provisions reserving the right to accept or reject an award or to enter into an agreement pursuant to an award, or any other unauthorized conditions, limitations or provisions.
 7. If the bidder is unable to evidence a satisfactory record of integrity.
 8. If the bidder is not qualified legally to contract.
 9. If the bid at the opening does not contain a signed bid, and a signed certificate of non-collusion.
- B. Utah County reserves the right to reject any or all bids.

1.9 DISPOSITION OF BIDS

All bids (and the information contained therein) shall become the property of Utah County. No bid shall be returned to the respondent regardless of the outcome of the selection process.

1.10 INTERPRETATION OF ITB

The invalidity of any portion of this ITB shall not prevent the remainder from being carried into effect. Whenever the context of any provision shall require it, the singular number shall be held to include the plural number, and vice versa, and the use of any gender shall include all genders. The paragraph and section headings in this ITB are for convenience only and do not constitute a part of the provisions hereof.

1.11 REQUIRED EXPERIENCE

- A. The Contractor must have a minimum of three (3) years experience in the work specified herein. Proof of experience must be submitted with each bid.
- B. The Contractor shall provide a list of at least three (3) projects similar to Utah County's as set forth herein, including contracting agency and contact information for each.
- C. The Contractor shall be the general contractor for the project and is required to have a current local business license from the jurisdiction in which their business is located. A copy of the bidder's current local business license must be submitted with the bid.

1.12 EVALUATION CRITERIA

All bids will be evaluated by authorized representatives of Utah County for compliance with the terms and conditions contained in this ITB and the resulting agreement awarded to the lowest responsive and responsible bidder. Utah County reserves the right to award to more than one Contractor if it is in the best interest of the County or to consider manufacturing and delivery times in contract award.

1.13 GENERAL

- A. Utah County will award a contract in reliance upon the information contained in bids submitted in response to the ITB. Utah County will be legally bound only when and if there is a signed agreement entered into between Utah County and the awarded bidder(s).
- B. It is vitally important that any person who signs a bid or agreement on behalf of a respondent certifies that he or she has the authority to so act. The bidder who has its bid accepted may be required to answer further questions and provide further clarification of its bid and responses.
- C. Receiving this ITB or responding to it does not entitle any entity to participate in services or transactions resulting from or arising in connection with this ITB. Utah County shall have no liability to any person or entity under or in connection with this ITB, unless and until Utah County and such person have executed and entered into an agreement pursuant to the terms of this ITB.
- D. By responding to this ITB each responding party acknowledges that neither Utah County nor any of its representatives is making or has made any representation or warranty, either express or implied, as to the accuracy or completeness of any portion of the information contained in this ITB. The responding party further agrees that neither Utah County nor any of its representatives shall have any liability to the responding party or any of its representatives as a result of this ITB process or the use of the information contained in this ITB. Only the terms and conditions contained in an agreement when, as, and if executed, and subject to such limitations and restrictions as may be specified therein, may be relied upon by the respondent in any manner as having any legal effect whatsoever.

1.14 BONDS

- A. Before this contract is awarded by Utah County, the Contractor shall furnish to Utah County the following bonds:
 - 1. A performance bond satisfactory to County in an amount equal to 100% of the price specified in the contract, to assure the faithful performance of the contract, for the protection of Utah County, to be held until final acceptance by Utah County of all aspects of this project; and
 - 2. A payment bond satisfactory to the County in an amount equal to 100% of the price specified in the contract, for the protection of each person supplying labor, service, equipment, or material for the performance of the work provided for in the contract.
- B. Each bond shall be:
 - 1. Binding upon the award of the contract;
 - 2. Executed by a surety company or companies duly authorized to do business in the State of Utah, or, in the form or cash or other certified funds;
 - 3. Payable to Utah County, A Body Corporate and Politic;
 - 4. Filed with the Utah County Public Works Department in a timely manner following the Closing date for Receipt of Bids; and
 - 5. Increased if the contract price is increased by change order or otherwise subsequent to entering into the contract.

- C. Utah County will hold the Payment Bond for 90 days subsequent to the completion of the project.

GENERAL REQUIREMENTS

Alteration of Plans or Character of Work

The County Commission, after recommendation by the County Public Works Director, reserves the right to make at any time during the progress of the work, such increases or decreases in quantities and such alterations in the details of construction, and the elimination of one or more items as may be found necessary or desirable. Such alterations shall not be considered as a waiver of nor release of the surety. The Contractor agrees to accept the work as altered the same as if it had been a part of the original Agreement. The Contractor shall proceed with the work alterations when ordered in writing. **Financial increases to this Agreement must be approved in writing by the County Commission before additional work is authorized and constructed.**

Brand Name

The use of brand names in the Specifications is for the purpose of designating the standard of quality, performance, and characteristics desired. Equivalent brand substitutions for products must be approved by Utah County.

Change Orders

Utah County may at any time, without notice to any sureties, by written order designated or indicated to be a change order, make changes to the work within the general scope of the contract and to the contract amount and/or contract deadlines.

The overhead, profit, and commission fees included in any change order bid shall not exceed the maximum percentages of the net cost of the bid as shown in the following table:

	Overhead & Profit	Commission
To prime Contractor on work performed by subcontractors	0%	10%
To prime Contractor or subcontractor for that portion of work performed with their respective forces	10%	0%

Only the Contractor or subcontractor who actually performs or furnishes the work may charge for overhead or profit regardless of the number of tiers of subcontractors, that is, the markup on work subcontracted by a subcontractor will be limited to one charge of 10% for overhead and profit and one charge of 10% for the prime Contractor's commission.

Overhead and profit includes but is not limited to:

1. Estimating

2. Field supervision above foreman level superintendents, assistant superintendents, general foremen, engineers, accountants, timekeepers, office manager, and other staff;
3. Office supplies
4. Drinking water
5. Temporary heat, light, and power
6. Field toilets
7. Small tools; and
8. Other costs of materials and/or equipment associated with performance of the contract.

On bids covering both increases and decreases in the contract amount, the overhead and profit shall be computed on the net change only.

Each change order shall be signed by the Contractor, the County Public Works Director, and the County Commission, and payment and performance bonds shall be increased by the Contractor to reflect any increase to the contract amount before the Contractor will be authorized to proceed with the work specified therein.

Failure of Contractor and the County to agree on an adjustment of contract amount or contract deadlines shall not excuse Contractor from proceeding with prosecution and performance of work. Contractors, subcontractors, and suppliers shall handle all disputes in a manner which will permit work to proceed on schedule while the matter in dispute is being resolved.

The County shall have the right, within its sole discretion, to require Contractor to commence performance of changes to work based on County requirements prior to the submission of a cost bid by the Contractor to the County, or approval of the cost bid by the County. In such case, Contractor shall proceed with the work so changed upon receipt of a Construction Change Directive from the County, and thereafter submit to the County as soon as possible any cost bid required.

Completion Date

The completion date for the 6400 South Bridge Replacement – Culvert Purchase will be evaluated based on the submitted bid schedule, regardless of weather conditions and other related problems. If the Contractor fails to complete the work on or prior to the completion date, or by extension of time granted by the County in writing, then the Contractor may forfeit his or her 5% payment retainer and shall in addition be liable for all additional costs and damages incurred by Utah County as a result of the failure of completion.

If abnormal weather conditions or other natural events totally beyond the control of the Contractor require, in the judgment of the County, an extension of the completion date, written authorization must be given by the County for such specific extension.

Liquidated Damages

It is agreed by the parties to this Agreement that in case all the work called for in accordance with this Agreement is not completed before or upon the Completion Dates set forth in this Agreement, damage will be sustained by Utah County, and that it is and will be

impracticable to determine the actual damage which Utah County will sustain in the event of and by reason of such delay, and it is therefore agreed that the Contractor will pay to Utah County **\$1860.00 per day** for each calendar day between the Completion Date required herein for any specific roadway and the date of final acceptance thereof by Utah County, as liquidated damages and not as penalty. It is further agreed that the amounts stipulated are reasonable estimates of the damages that would be sustained by Utah County and the Contractor agrees to pay such liquidated damages as herein provided. In case the liquidated damages are not paid, the Contractor agrees that Utah County may deduct the amount thereof from any money due to or that may become due to the Contractor by progress payments or otherwise in accordance with the terms of this Agreement, or if said amount is not sufficient, recover the total amount.

The Contractor will not be assessed with liquidated damages during any delay in the completion of the work caused by acts of God, acts of criminals, acts of Utah County, acts of the public utilities, fire, floods, epidemics, quarantine restrictions, labor strikes that delay the critical sequence of the work, and unusually severe weather or delays of subcontractors due to such causes, provided that Utah County is notified in writing of the causes of such delay.

Cooperation

Utah County intends to encourage cooperation with the Owner, Engineers, Supplier, Contractor and its subcontractors. The objectives are effective and efficient agreement performance, intended to achieve completion within budget, on schedule, and in accordance with the Drawings and Specifications.

Alternative Dispute Resolution (ADR) methodologies will be encouraged in place of the more formal dispute resolution procedures. ADR in this context is intended to be a voluntary, non-binding procedure available for use by the parties to this Agreement to resolve any dispute that may arise during performance.

Delivery/Shipping

The Contractor/Supplier shall be responsible for all delivery, shipping, transportation, and handling charges and shall include these costs in the bid schedule. Delivery and Shipping costs will not be paid as a separate line item.

Extra Work

If extra work, as defined in the Utah County Standard Terms and Conditions, is authorized by the Utah County Commission in writing, payment for authorized extra work will be made by either of the following methods, as determined by the County:

1. Reimbursement for all direct and substantiated costs of labor, materials, supplies and equipment use, plus 10% to cover all indirect costs, overhead and profit; or
2. A lump sum, agreed to prior to beginning the extra work, to cover all of the items authorized in writing by the County.

Inspection

Testing or work to determine contract compliance shall be performed by the Contractor. Such testing shall comply with APWA standards for all applicable materials and placement of those materials. Copies of test results must be provided to, and approved by, the County Project Manager prior to final acceptance of project.

Final acceptance and inspection of completed work shall be performed by the County Project Manager.

Insurance

The insurance required by the Utah County Standard Terms and Conditions shall name "Utah County, 100 East Center, Provo, Utah 84606" as a Certificate Holder.

The Contractor shall file all required certificates of insurance with the Utah County Public Works Department in a timely manner following the Closing Date for Receipt of Bids and prior to commencing any work.

Keys

If it becomes necessary for the County to issue the Contractor a key to County locks, final payment to the Contractor will be held until the key has been returned and documented. It is illegal to duplicate County keys.

Legal

The Contractor shall be responsible to provide all legal support for the project including but not limited to the preparation of contracts with subcontractors.

License

The Contractor shall have a current "Business License", issued by the county or city in which the Contractor's business is located, and shall provide proof of such license prior to the commencement of said work.

The Contractor shall be a licensed "General Contractor" through the State of Utah, Utah Division of Occupational and Professional Licensing, to perform construction work in this State. The Contractor shall provide proof of such license prior to the commencement of said work.

Payment

Payment shall be required in the manner proscribed in the Utah County Standard Terms and Conditions. All bills must be signed and dated by both the Contractor and the County Project Manager before the payment process can commence. Each bill shall itemize the work performed and shall show progress of the work that can be verified. Actual payment will be based upon inspection by the County Project Manager who will certify that the work has

been performed in a workmanlike manner. **In accordance with Utah Code §13-8-5, Utah County may retain five percent (5%) of all payments to the Contractor or such other sums as authorized thereby until the end of the project.** Final payment of any sums retained will be paid thirty (30) days after request after approval of work by final inspection.

The County Project Manager will decide all questions which may arise as to the quality, quantity and acceptability of materials furnished and work performed and as to the rate of progress of work. He will also decide all questions which may arise as to the acceptable fulfillment of the Agreement on the part of the Contractor.

Payments may be withheld from the Contractor by the County in order to protect or offset the County from loss due to:

1. Defective work not remedied.
2. Liens or claims filed or reasonable evidence of probable filing.
3. The Contractor's failure to promptly pay subcontractors for labor and/or materials accepted by the Contractor.
4. The County's reasonable doubt that the project can be completed for the unpaid balance of the contract price.
5. Damage to another contractor.
6. Failure to maintain scheduled progress.
7. Any other failure of the Contractor which results in liability for the County.

Safety Requirements

In order to protect the life and health of employees and the general public in the performance of this Agreement, the Contractor shall comply with the general safety orders covering Utah industries, issued by the Industrial Commission of Utah and Occupational Safety and Health Act of 1970. Nothing in the Agreement shall relieve the Contractor of responsibility assigned in the Specifications, State Industrial Commission's requirements, or state and local laws and ordinances.

The Contractor agrees to hold Utah County and the County's Engineer free and harmless from any and all damages/claims that may occur during the construction operations of this Agreement. The Contractor shall assume sole liability for any injuries or damages caused to a third party as a result of fulfillment of this Agreement and construction operations.

The County Public Works Director or the County Project Manager will have the authority by written order to suspend work wholly or in part due to the failure of the Contractor to correct conditions unsafe for the workmen or general public; for failure to carry out provisions of the

Agreement; for failure to carry out orders; for such periods as he may deem necessary due to unsuitable weather, for conditions considered unsuitable for the progress of the work, or for any other condition or reason deemed to be in the public interest. Written orders shall state the reason for suspension.

Sales Tax

The Contractor shall be responsible for including in their bid schedule, not as a separate line, any sales tax charges for products, materials, or other items that the Contractor will be purchasing. The Contractor will not be allowed to use the County's sales tax exemption number to purchase products, materials or other items that the Contractor will be installing as part of the agreement on the County's behalf.

Supervision of Work

The County Public Works Director shall have full supervisory powers in determining the extent of the construction on the project. Compensation shall be based upon logbooks maintained by the County Project Manager as a percentage of work completed and payment terms described under General Requirements. All decisions concerning the extent and acceptability of the work and the quality of all materials shall rest solely with the County Public Works Director.

Surveying

The Contractor shall be responsible for all construction staking.

The Contractor will be responsible for furnishing, maintaining, or restoring all survey monuments and reference marks within the project site. Contact the County Surveyor to obtain permits for section corners and monuments before any work begins.

Utilities

Care shall be taken to preserve and protect existing overhead and underground utilities, pole lines, signs, pipelines, and improvements from injury or damage during construction operations. The Contractor shall assume full responsibility for reimbursing the owners of the utilities for any damage to their properties, utilities, or improvements, or interference with their service caused through Contractor's operations at no additional cost to the County. **The Contractor shall contact "Blue Stakes of Utah,"** and individual utility owners as necessary, to have all underground utilities located on the work site in accordance with Utah law.

The Contractor shall be responsible to protect in place all utilities shown or not shown on this plan.

The Contractor shall be responsible for providing all water, power, sanitary facilities, and telephone services as required for the Contractor's use during construction.

ATTACHMENT A

CONTRACTOR'S BID SCHEDULE

Company Name: _____
Address: _____
City, State, Zip: _____
Phone: _____

B.1 BID PRICE:

Each Bidder shall complete the line-item cost summary below. The specified "Total Cost" shall become the bidder's "Total Bid Price" for completion of this project.

6400 South Bridge Replacement – Culvert Purchase

Item	APWA	DESCRIPTION	Unit	ESTIMATED QUANTITY	UNIT PRICE	AMOUNT
1	01 65 00	Delivery	Lump	1		
2		6'X24' Box Culvert	Feet	71		
3		Headwalls, Wing Walls, with Parapets (one side)	Each	2		
					TOTAL COST:	

NOTE: The quantities specified herein are only estimates used for bid evaluation purposes. Actual payment will be based upon inspection records kept by the County, and the actual work completed, approved, and accepted by the County.

B.2 SCHEDULE:

Each Bidder shall provide an anticipated duration for completion and delivery of the culvert sections, wing walls, and headwalls, from the time of contract award in weeks.

B.3 CERTIFICATION

I hereby certify that I have read, understand, and agree to all sections, Exhibits, Addenda, and Attachments of this Invitation to Bid for 6400 South Bridge Replacement – Culvert Purchase. I further certify that the information submitted by me/my company in response to this Invitation, including the pricing and other information, is true and accurate.

I understand that Utah County has the right to reject any or all bids, to waive minor irregularities when to do so would be in the best interests of Utah County, and to negotiate a price for the proposed services as determined to be in the best interest of Utah County.

Signature

Title

Name (please print)

Date

ATTACHMENT B
SPECIFICATIONS
MEASUREMENT & PAYMENT

1.	DELIVERY (Lump)	APWA 01 65 00
-----------	------------------------	----------------------

Payment includes all costs incidental to delivering products to the project site to avoid conflict with work. Must coordinate with selected installation contractor for delivery schedule, location and sequence. Approximate location for delivery is in unincorporated Utah County where 6400 South crosses the Benjamin Slough in the Lake Shore area.

2.	6'x24' BOX CULVERT (Feet)
-----------	----------------------------------

Payment includes all costs of providing a precast reinforced concrete box culvert, fitting and joint material that complies with AASHTO LRFD Bridge Design Specification and designed for HL-93 live loading. Payment also includes providing structural calculations for the precast element.

3.	WING WALLS and HEADWALLS WITH PARAPETS (Each)
-----------	--

Payment includes the cost of providing precast headwalls and wing walls with parapets that comply with AASHTO LRFD Bridge Design Specification. Payment also includes providing structural calculations for the precast elements.

ATTACHMENT C
SPECIFICATIONS

SECTION 01 11 00
SUMMARY OF WORK

PART 1 GENERAL

The Contractor shall carefully read all notes and specifications. The Contractor shall be satisfied as to the true meaning and intention and shall be responsible for complying with each.

1.1 GENERAL NOTES

- A. Manufacturing and delivery times are a critical part of the project schedule and will be a consideration in awarding of the project.

1.2 APWA STANDARDS SPECIFICATIONS

- A. All work performed by the Contractor shall meet or exceed all applicable specifications listed in the publications American Public Works Association – Manual of Standard Specifications and Manual of Standard Plans, 2017 edition, published by the Utah Chapter of the American Public Works Association, hereinafter referred to as “APWA Standard Specifications and Standard Plans.” All work performed by the Contractor shall also comply in every respect with the “6400 South Bridge Replacement” (the drawings), which are attached hereto and incorporated herein by this reference. Where conflicts arise, the most stringent code will apply.
- B. Where the plans or specifications describe portions of the work in general terms but not complete detail, it is understood that only the best general practice is to prevail and that only materials and workmanship of the first quality are to be used.
- C. It is intended that these plans and specifications require all labor and materials necessary and proper for the work contemplated and that the work be completed in accordance with their true intent and purpose. The contractor shall notify the engineer immediately regarding any discrepancies or ambiguities which may exist in the plans or specifications. The engineer's interpretation thereof shall be conclusive.

1.3 SAFETY

- A. The Contractor shall comply with all applicable requirements of the Utah Labor Commission and the Occupational Safety and Health Act of 1970. Nothing in this Agreement shall relieve the Contractor of responsibility assigned herein, in Utah Labor Commission's requirements, or in Federal, state, and local laws and ordinances.

1.4 PERMITS

- A. Not Applicable

END OF SECTION

SECTION 01 65 00
PRODUCT DELIVERY AND HANDLING

PART 1 GENERAL

1.1 SECTION INCLUDES

- A. Basic requirements for product delivery and handling on site.

1.2 DELIVERY

- A. Arrange for delivery of products in accordance with progress schedule to facilitate instruction before installation.
- B. Coordinate deliveries to avoid conflict with work, conditions at site, and:
 - 1. Work of separate contractors, or OWNER.
 - 2. Limitations of storage space.
 - 3. OWNER's use of premises.
- C. Deliver products in undamaged condition in original containers or packaging, with identifying labels for handling, storing, unpacking, protecting and installing intact and legible.
- D. Partial deliveries of component parts of equipment shall be clearly marked to identify the equipment, to permit easy accumulation of parts, and to facilitate assembly.
- E. Immediately upon delivery, inspect shipment to determine:
 - 1. Product complies with requirements of Contract Document
 - 2. Reviewed submittals.
 - 3. Quantities are correct.
 - 4. Containers and packages are intact, labels are legible.
 - 5. Products are properly protected and undamaged.

1.3 PRODUCT HANDLING

- A. Schedule delivery to minimize long-term storage at the site and to prevent overcrowding of construction space.
- B. Coordinate delivery with installation time to ensure minimum holding time for items that are hazardous, easily damaged, or sensitive to deterioration, theft and other losses.
- C. Handle products to prevent bending or over-stressing.
- D. Lift heavy components at designated lifting points.
- E. Discard damaged products.

1.4 ACCESS

- A. Identify access to CONTRACTOR's work and office area by use of signs so agents, delivery trucks, and other parties desiring contact with CONTRACTOR may do so.
- B. In security zones, prevent unauthorized personnel from proceeding outside of CONTRACTOR's work and office areas.

END OF SECTION

PRECAST CONCRETE BOX AND THREE-SIDED CULVERT STRUCTURES

PART 1 GENERAL

1.1 SECTION INCLUDES

- A. Material and procedures for fabricating and installing single cell precast concrete box culverts, multi-cell precast concrete box culverts, precast conventionally reinforced concrete three-sided culvert structures, and ancillary appurtenances such as cutoff walls, aprons, footings, floor slabs, headwalls and wing walls.

1.2 REFERENCES

- A. AASHTO LRFD Bridge Design Specifications
- B. ASTM C150: Standard Specification for Portland Cement
- C. ASTM C877: External Sealing Bands for Concrete Pipe, Manholes, and Precast Box Sections
- D. ASTM C990: Joints for Concrete Pipe, Manholes, and Precast Box Sections Using Preformed Flexible Joint Sealants
- E. ASTM C1504: Manufacture of Precast Reinforced Concrete Three-Sided Structures for Culverts and Storm Drains
- F. ASTM C1577: Precast Reinforced Concrete Monolithic Box Sections for Culverts, Storm Drains, and Sewers Designed According to AASHTO LRFD.
- G. OSHA

1.3 SUBMITTALS

- A. Detailed plans including culvert sizes and wall widths, line layout, joint details and lifting devices.
- B. Structural calculations for the precast element. ASTM C1577 steel areas may be used for box culverts without providing supporting calculations. For special designs, for sizes and loads other than those shown in Table 1 of ASTM C1577, engineering calculations will be required. Eriksson Culvert software design calculations may be submitted for approval of steel areas for box culverts.
- C. For Three Sided Structures, design the structure in compliance with AASHTO LRFD Bridge Design Specifications, Section 12. Computer aided design calculations may be submitted. Design for HL-93 live loading.
- D. Provide the seal of a Professional Engineer (PE) licensed in the appropriate state on drawings and supporting engineering calculations.
- E. Allow the Engineer up to seven calendar days to review and approve working drawings and supporting engineering calculations.
- F. Foundation material gradation (for over excavation replacement), bedding material gradation or leveling course gradation will be submitted for the Engineers approval.

PART 2 PRODUCTS

2.1 CONCRETE

- A. Provide strength and size of the culvert or structure.
- B. Use ASTM C150, ASTM C1157, or ASTM C595 cement unless otherwise specified.
- C. Meet the concrete performance requirements per the appropriate manufacturing specification, either ASTM C1577 or ASTM C1504.

2.2 REINFORCING

- A. Use steel bars or steel welded wire.

2.3 JOINTS

- A. Use tongue and groove joints with a bituminous mastic joint sealant that meets the requirements of ASTM C990.
- B. Use a mastic joint sealant with a minimum cross-sectional area of 1 to 1½ square inches.
- C. Joint wrap is not required. Use ASTM C877 if joint wrap is specified.
- D. Mortar grout is not required.

2.4 LIFTING DEVICES

- A. Provide the number and type of lifting devices required to support the vertical and horizontal forces
 - 1. Use at least four lifting devices for box culvert and three-sided structures.
 - 2. Use a minimum safety factor of 4:1 for lifting inserts used in handling and erection of precast concrete box culverts and three-sided structures.
 - 3. Attach to lifting inserts according to manufactures recommendations.
 - 4. Use a maximum diameter of 3 inches when lifting holes are used. Locate holes to avoid interference with the reinforcing steel.

2.5 MANUFACTURE

- A. Precast Concrete Box Culverts:
 - 1. Meet the requirements in ASTM C1577.
 - 2. Special designs for sizes and loads other than those shown in Table 1 of ASTM C1577 require approval by the Engineer.
 - 3. Prepare special designs according to AASHTO LRFD Bridge Design Specifications, Section 12.
- B. Precast Concrete Three-Sided Structures:
 - 1. Meet the requirements in ASTM C1504 with the following exceptions:
 - a. Design the structure in compliance with AASHTO LRFD Bridge Design Specifications, Section 12.
 - b. Design for HL-93 live loading.

2.6 QUALITY ASSURANCE

- A. Manufacture of pre-cast concrete box and three-sided culvert section must be completed in a plant where the quality assurance program has been certified by either the American Concrete Pipe Association (for box culverts) or the National Precast Concrete Association (for three sided structures).
- B. Permanently mark each precast unit with date of casting and supplier identification.
- C. Prevent cracking or damage during shipping, handling and storage of precast units.
- D. Replace or repair, cracked or damaged precast units at no additional cost to the Owner.

2.7 CONNECTION TO CAST-IN-PLACE CONCRETE

- A. Project the reinforcing steel at least 12 inches out of the precast box section and square off the concrete face where precast box sections join cast-in-place concrete.

END OF SECTION

ATTACHMENT D
90% PLANS & DRAWINGS

6400 SOUTH BRIDGE REPLACEMENT

90% DESIGN

UTAH COUNTY NEAR BENJAMIN, UTAH

JUNE, 2024



VICINITY MAP

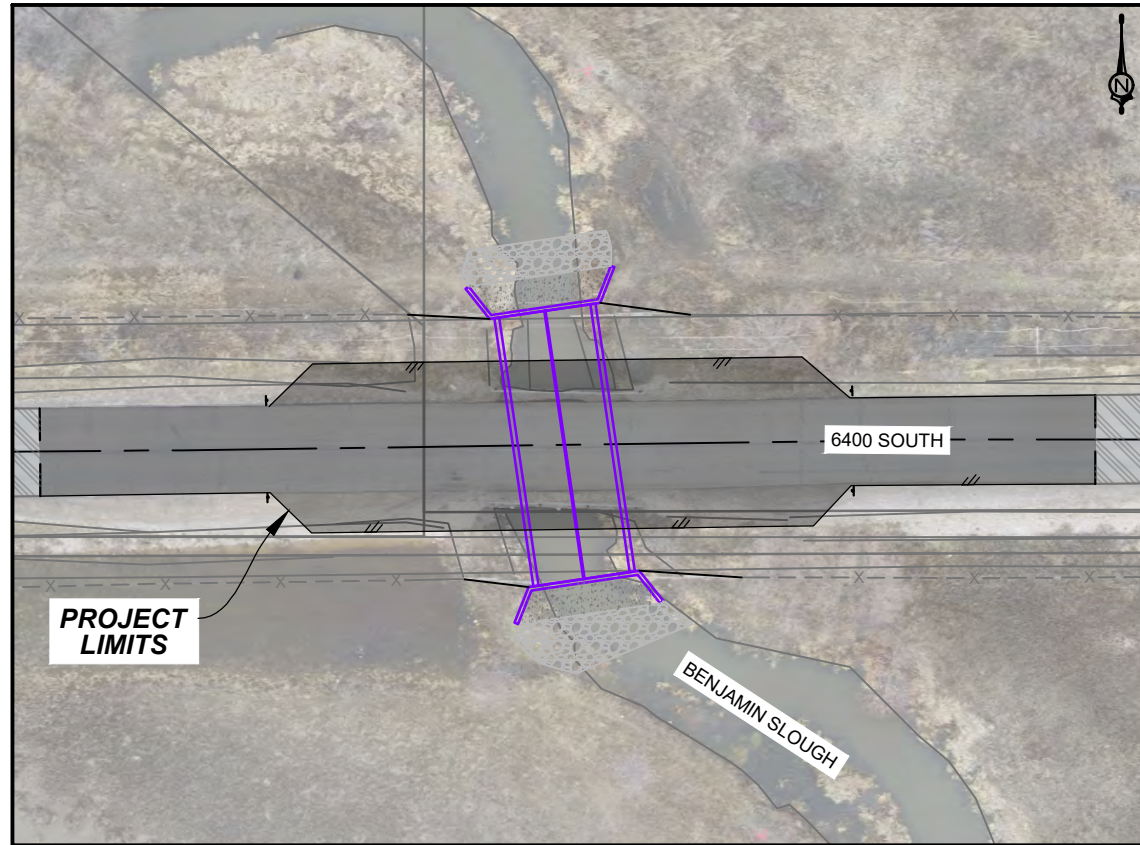

PROJECT MAP

SHEET INDEX		
SHEET NO.	SHEET	SHEET TITLE
1	CV01	COVER
2	GN01	GENERAL NOTES
3	GN02	LEGEND & ABBREVIATIONS
4	DM01	DEMOLITION PLAN
5	TC01	TEMPORARY CONSTRUCTION STAGING PLAN
6	PP01	PLAN & PROFILE
7	ST01	PRECAST RCB SITUATION AND LAYOUT
8	ST02	PRECAST RCB SITUATION AND LAYOUT



90% BID SET NOT FOR CONSTRUCTION			
NO.	DESCRIPTION	BY	DATE

COVER

6400 SOUTH BRIDGE REPLACEMENT
UTAH COUNTY NEAR BENJAMIN, UTAH

PROJ. # IF 24060.01
DATE: JUNE, 2024
DESIGN BY: TPB
CHECKED BY: JGJ
SHEET
CV01
1 OF 8

PLOT: 2024-06-04 02:17 PM
PATCH: \UTAH\DESIGN\ACTIVE\2024\IF\24060.01 - 6400 SOUTH BRIDGE REPLACEMENT\700 - CAD\SHEET - FILE\24060 - CV.DWG



PLOT: 2024-06-04 02:17 PM
PATH: I:\UTAH\PROJECTS\ACTIVE\2024\FF\6400.01 - 6400 SOUTH BENJAMIN'S LOUGH BRIDGE REPLACEMENT\100 - CAD\SHSHEET_FILES\64000_CV.DWG

GENERAL PROJECT NOTES

1. ALL CONSTRUCTION AND MATERIALS SHALL CONFORM WITH THE CURRENT UTAH COUNTY STANDARDS AND SPECIFICATIONS AND WITH ALL OTHER APPLICABLE FEDERAL, STATE AND LOCAL ORDINANCES AND LAWS.
2. THE CONTRACTOR SHALL OBTAIN ALL PERMITS NECESSARY TO COMPLETE THE CONSTRUCTION.
3. THE TERM ENGINEER HEREIN REFERS TO THE CONSTRUCTION ENGINEER. COORDINATE ALL WORK WITH ENGINEER AND INSPECTORS. UTAH COUNTY ENGINEER IS CALLED OUT SEPARATELY IN THESE DOCUMENTS.
4. THE CONTRACTOR SHALL COORDINATE SITE CONSTRUCTION WITH ALL UTILITY CONSTRUCTION AND OTHERS WHICH MAY BE SPECIFIC TO THE PROJECT.
5. THE CONTRACTOR IS RESPONSIBLE FOR DUST ABATEMENT AND ANY LIABILITY ISSUES RELATED TO DUST WITHIN THE PROJECT LIMITS.
6. ALL WORK SHALL BE COMPLETED WITHIN THE PUBLIC RIGHT-OF-WAY AND WITHIN TEMPORARY CONSTRUCTION EASEMENTS. THE CONTRACTOR SHALL TAKE EVERY PRECAUTION TO ELIMINATE ANY ADVERSE EFFECTS ON ADJACENT PROPERTIES AND/OR RESTORE IT TO ITS ORIGINAL CONDITION.
7. THE OFFICE OF THE UTAH COUNTY ENGINEER, PUBLIC WORKS DIRECTOR, AND CONSTRUCTION ENGINEER SHALL BE GIVEN AT LEAST ONE (1) WEEK'S NOTICE PRIOR TO BEGINNING ANY CONSTRUCTION. ALL WORK SHALL BE DONE IN ACCORDANCE WITH THE APPROVED PLANS AND SPECIFICATIONS.
8. DEVIATION FROM THESE PLANS AND SPECIFICATIONS WITHOUT THE PRIOR WRITTEN CONSENT OF THE ENGINEER MAY CAUSE THE WORK TO BE DEEMED UNACCEPTABLE.
9. THE CONTRACTOR IS RESPONSIBLE FOR NOTIFICATIONS AND LIAISON WITH UTILITY COMPANIES IN THE PROCESS OF LOCATING, RELOCATION, AND TIE-IN TO PUBLIC UTILITIES. ALSO, THE CONTRACTOR IS RESPONSIBLE FOR NOTIFYING ALL INSPECTORS, INCLUDING THE ENGINEER PRIOR TO BEGINNING SITE CONSTRUCTION.
10. IN THE CASE OF UNFORESEEN CONSTRUCTION COMPLICATIONS OR DISCREPANCIES, THE CONTRACTOR IS TO NOTIFY THE ENGINEER IMMEDIATELY AND PROVIDE NECESSARY DOCUMENTATION FOR EVALUATION AND DIRECTION.
11. THE PLANS WERE PREPARED IN ACCORDANCE WITH ESTABLISHED PRACTICES OF CIVIL ENGINEERING DESIGN. THE ENGINEER NOR ITS PERSONNEL CAN OR DO WARRANT THESE PLANS AS CONSTRUCTED EXCEPT WHERE THE ENGINEER INSPECTS AND CONTROLS THE PHYSICAL CONSTRUCTION ON A TEMPORARY BASIS AT THE SITE.
12. COORDINATE ALL CONSTRUCTION WORK ON PRIVATE PROPERTY WITH LOCAL RESIDENCES OR BUSINESSES. ANY CLOSURE OF AN ACCESS TO A RESIDENCE OR A BUSINESS REQUIRES 48 HOUR NOTICE (MIN.), AND SHALL BE COORDINATED WITH THE PROPERTY OWNER, AND PERMISSION GRANTED FROM THE PROPERTY OWNER, BEFORE ANY WORK CAN COMMENCE AT THE ACCESS LOCATION.
13. FINAL QUANTITIES AND PROJECT LOCATIONS WILL BE DEPENDENT UPON BIDS AND THE PROJECT BUDGET.
14. A PRE-CONSTRUCTION MEETING WILL BE REQUIRED PRIOR TO CONSTRUCTION. COORDINATE WITH UTAH COUNTY FOR TIME AND LOCATION.

CONSTRUCTION SITE SAFETY

1. THE CONTRACTOR IS REQUIRED TO MEET ALL APPLICABLE REGULATIONS CONCERNING PROJECT SAFETY AND ASSUMES FULL RESPONSIBILITY FOR SAFETY ON THE PROJECT.
2. WORKERS AND THE PUBLIC SHALL BE PROTECTED BY THE CONTRACTOR FROM ANY AND ALL HAZARDS CONNECTED WITH THE CONSTRUCTION WORK.
3. OPEN TRENCHES, MATERIALS, OR EQUIPMENT WITHIN THE WORKING LIMITS ARE TO BE PROTECTED BY THE USE OF ADEQUATE BARRICADES.
4. ALL WORK SHALL BE IN CONFORMANCE WITH CURRENT OSHA REGULATIONS FOR PROJECTS OF THIS TYPE.
5. IN ACCORDANCE WITH GENERALLY ACCEPTED CONSTRUCTION PRACTICES, THE CONTRACTOR SHALL BE SOLELY AND COMPLETELY RESPONSIBLE FOR THE CONDITIONS OF THE JOB SITE, INCLUDING THE SAFETY OF ALL PERSONS AND PROPERTY DURING PERFORMANCE OF THE WORK. THIS REQUIREMENT SHALL APPLY CONTINUOUSLY AND SHALL NOT BE LIMITED TO NORMAL WORKING HOURS. ANY CONSTRUCTION OBSERVATION BY THE ENGINEER OF THE CONTRACTOR'S WORK IS NOT INTENDED TO INCLUDE THE ADEQUACY OF THE CONTRACTOR'S SAFETY MEASURES EITHER, ON, OR NEAR THE CONSTRUCTION SITE.

TRAFFIC CONTROL AND SIGNAGE

1. THE CONTRACTOR SHALL MAINTAIN INGRESS/EGRESS ACCESS TO INDIVIDUAL PROPERTY OWNERS AT ALL TIMES. THE CONTRACTOR SHALL COORDINATE DETOURS AND ANY TEMPORARY CLOSURES WITH EACH PROPERTY OWNER AND THE UTAH COUNTY ENGINEERING DEPARTMENT. THE CONTRACTOR SHALL KEEP DURATION OF ALL CLOSURES AND DETOURS TO A MINIMUM. SEE GENERAL CONDITIONS FOR ROAD CLOSURE INFORMATION. MAINTAIN ACCESS FOR EMERGENCY VEHICLES THROUGHOUT PROJECT CONSTRUCTION.
2. THE CONTRACTOR SHALL FOLLOW THE CURRENT EDITION OF THE MANUAL ON UNIFORM TRAFFIC CONTROL DEVICES (MUTCD) STANDARDS AND GUIDES FOR TRAFFIC CONTROL FOR STREET AND HIGHWAY CONSTRUCTION. ALL TRAFFIC CONTROL PLANS REQUIRE UTAH COUNTY APPROVAL.

STORM WATER POLLUTION PREVENTION

1. PRIOR TO ANY LAND DISTURBANCE OR CITY EXCAVATION PERMIT, THE CONTRACTOR WILL PREPARE AND SUBMIT A SWPPP DOCUMENT AND OBTAIN AN NPDES PERMIT. THE CONTRACTOR WILL BE REQUIRED TO KEEP THE SWPPP ON SITE AT ALL TIMES AND ABIDE BY IT. THE SWPPP SHALL MEET ALL REQUIREMENTS OF THE STATE CONSTRUCTION GENERAL PERMIT.

PROTECTION OF EXISTING UTILITIES AND MONUMENTS

1. A MINIMUM 48 HOUR NOTICE IS REQUIRED TO ALL AFFECTED RESIDENTS FOR UTILITY OUTAGES.
2. UTILITIES INFORMATION SHOWN HEREON WERE OBTAINED FROM THE BEST AVAILABLE SOURCES AND MAY NOT BE EITHER ACCURATE OR COMPLETE. THE LOCATION OF EXISTING UNDERGROUND UTILITIES ARE SHOWN IN AN APPROXIMATE WAY ONLY AND HAVE NOT BEEN INDEPENDENTLY VERIFIED BY THE OWNER OR ITS REPRESENTATIVES. THE CONTRACTOR SHALL DETERMINE THE EXACT LOCATION OF ALL EXISTING UTILITIES BEFORE COMMENCING WORK. UNDERGROUND LOCATES MAY BE MADE USING THE BLUE STAKES NUMBER 1-800-662-4111 OR 811.
3. WHERE EXISTING UTILITY WIRES (TELEPHONE, ELECTRIC) ARE LOCATED ADJACENT TO OR ABOVE THE PROPOSED STORM DRAIN OR WATER PIPELINES, THE CONTRACTOR SHALL TEMPORARILY SUPPORT THE EXISTING WIRES AND INSTALL MAIN PIPING AT THE CONTRACTOR'S EXPENSE.
4. THE CONTRACTOR SHALL PROTECT ALL SURVEY MONUMENTS NOT CALLED OUT FOR RECONSTRUCTION. ANY MONUMENTS DISTURBED OR DESTROYED SHALL BE REPLACED BY THE OWNER'S REPRESENTATIVE AT THE CONTRACTOR'S EXPENSE.

REMOVALS

1. ANY EXISTING STRUCTURES OR SURFACE FEATURES DISTURBED BY CONSTRUCTION ARE TO BE RESTORED TO THEIR ORIGINAL LOCATION AND CONDITION. ALL STRUCTURES SUCH AS CURB AND GUTTER, CONCRETE AND BITUMINOUS SIDEWALKS, PAVING BRICKS, FENCING, RETAINING WALLS, ETC., CROSSED BY THE PROPOSED STORM DRAIN MAY NOT BE INDICATED.
2. EXCESS EXCAVATED MATERIALS INCLUDING PIPE, STUMPS, ROOTS, SOIL MATERIALS OR ANY OTHER ITEMS THE OWNER DOES NOT WISH TO SALVAGE SHALL BECOME THE CONTRACTOR'S PROPERTY AND SHALL BE REMOVED FROM THE SITE AND DISPOSED OF PROPERLY. INCIDENTAL TO THE CONTRACT. ASPHALT AND CONCRETE SHALL BE DISPOSED OF OFFSITE INCIDENTAL TO THE CONTRACT. THE CONTRACTOR IS REQUIRED TO USE A LICENSED SOLID WASTE COLLECTION AND DISPOSAL SERVICE FOR ALL WASTE GENERATED FROM THE CONSTRUCTION SITE.

PERMITS REQUIRED

1. EXCAVATION PERMIT
 - OBTAINED BY CONTRACTOR AT COUNTY
2. UTAH POLLUTANT DISCHARGE ELIMINATION SYSTEM (UPDES) STORM WATER PERMIT
 - OBTAINED BY THE CONTRACTOR
3. SPECIAL USE PERMIT
 - OBTAINED BY THE COUNTY
4. LICENSE AGREEMENT
 - OBTAINED BY THE COUNTY
5. STREAM ALTERATION PERMIT
 - OBTAINED BY THE COUNTY



3160 W. Clubhouse Drive, Ste. A
Lehi, UT 84043
801.788.7200

90% BID SET
NOT FOR CONSTRUCTION

NO.	DESCRIPTION	BY	DATE

GENERAL NOTES

6400 SOUTH BRIDGE REPLACEMENT
UTAH COUNTY NEAR BENJAMIN, UTAH



Know what's below.
Call before you dig.

PROJ. #: FF 24060.01
DATE: JUNE, 2024
DESIGN BY: TPB
CHECKED BY: JGJ

SHEET

GN01

2 OF 8

PLOT: 2024-06-04 02:17 PM
 PATH: \\UTAHREGIS\ACTIVE\2024\06\01-6400 SOUTH BRIDGE REPLACEMENT\DRAWING\LEGEND.DWG

ABBREVIATIONS		ABBREVIATIONS		ABBREVIATIONS	
AC	ACRE	HDPE	HIGH-DENSITY POLYETHYLENE	SS	SANITARY SEWER
AGGR	AGGREGATE	HMA	HOT MIX ASPHALT	ST	STREET
ALGN	ALIGNMENT	HOR	HORIZONTAL	STA	STATION
ALT	ALTERNATE	HP	HIGH POINT	STD	STANDARD
APPR	APPROXIMATE	HYD	HYDRANT	SW	SIDEWALK
ASSY	ASSEMBLY	IN	INCH	SF/SQ YD	SQUARE YARD
AVE	AVENUE	IN	INCH	TA	TOP OF ASPHALT
BFV	BUTTERFLY VALVE	ID	INSIDE DIAMETER	TBC/TC	TOP BACK OF CURB
BH	BORE HOLE	INV	INVERT	TBR	TO BE REMOVED
BITUM	BITUMINOUS	IRR	IRRIGATION	T.O.P.	TOP OF PIPE
BK	BACK	LEN	LENGTH	TW	TOP OF WALL
BOA	BEGINNING OF ALIGNMENT	LF	LINEAR FEET	TYP.	TYPICAL
BSW	BACK OF SIDEWALK	LP	LOW POINT	VAR.	VARIES
BVC	BEGIN VERTICAL CURVE	LT	LEFT	VERT.	VERTICAL
BW	BOTTOM OF WALL	LVC	LENGTH OF VERTICAL CURVE	WAT.	WATER
C&G	CURB AND GUTTER	WL	WATER LINE		
CB	CATCH BASIN	MAX	MAXIMUM		
C-C	CENTER TO CENTER	MFR	MANUFACTURER		
CF	CUBIC FEET	MH	MANHOLE		
CFS	CUBIC FEET PER SECOND	MIN	MINIMUM		
CI	CAST IRON	MJ	MECHANICAL JOINT		
CIP	CAST IRON PIPE	N	NORTH		
CL	CENTERLINE	NO	NUMBER		
CMP	CORRUGATED METAL PIPE	NTS	NOT TO SCALE		
CO	CLEANOUT	OC	ON CENTER		
COMM	COMMUNICATION	OD	OUTSIDE DIAMETER		
CONC	CONCRETE	OH	OVERHEAD		
CONST	CONSTRUCTION	OSHA	OCCUPATION SAFETY AND HEALTH ADMINISTRATION		
CU	COPPER	OWE	OVERFLOW WATER ELEVATION		
CY/CU YD	CUBIC YARD	PC	POINT OF CURVATURE		
DBL	DOUBLE	PCC	POINT OF COMPOUND CURVATURE		
DI	DUCTILE IRON	PI	POINT OF INTERSECTION		
DIAD	DIAMETER	PL	PROPERTY LINE		
DIP	DUCTILE IRON PIPE	POLY	POLYETHYLENE		
DR	DRIVE	POT	POTABLE		
DRWY	DRIVEWAY	PP	POWER POLE		
DWG	DRAWING	PRC	POINT OF REVERSE CURVATURE		
E	EAST	PRV	PRESSURE REDUCING VALVE		
EA	EACH	PSI	POUNDS PER SQUARE INCH		
EG	EXISTING GRADE	PT	POINT OF TANGENCY		
EP/EOP	EDGE OF PAVEMENT	PVC	POLYVINYL CHLORIDE		
ELEC	ELECTRICAL	PVI	POINT OF VERTICAL INTERSECTION		
EL/ELEV	ELEVATION	PUE	PUBLIC UTILITY EASEMENT		
EX	EXISTING	RAD/R	RADIUS		
OHEL	OVERHEAD ELECTRICAL	RCB	REINFORCED CONCRETE BOX		
EOA	END OF ALIGNMENT	RCP	REINFORCED CONCRETE PIPE		
ESMT	EASEMENT	REQ'D	REQUIRED		
EVC	END VERTICAL CURVE	ROW	RIGHT-OF-WAY		
EX/EXIST	EXISTING	RR	RAILROAD		
FEMA	FEDERAL EMERGENCY MANAGEMENT AGENCY	RT	RIGHT		
FES	FLARED END SECTION	ALT.	SOUTH		
FG	FINISHED GRADE	SAN	SANITARY		
FH	FIRE HYDRANT	SCH.	SCHEDULE		
FIRM	FLOOD INSURANCE RATE MAP	SD	STORM DRAIN		
FL	FLOWLINE	SDR	STANDARD DIMENSION RATIO		
FM	FORCE MAIN				
FO	FIBER OPTIC				
FS	FINISHED SURFACE				
FT	FOOT/FEET				
GALV	GALVANIZED				
GB	GRADE BREAK				
GR	GRATE	SF/SQ FT	SQUARE FEET		
GV	GATE VALVE	SHT	SHEET		
		SIM.	SIMILAR		

LEGEND		EXISTING	PROPOSED	
				MAJOR CONTOUR
				MINOR CONTOUR
				CURB AND GUTTER
				EDGE OF PAVEMENT
				EDGE OF GRAVEL
				STREET CENTERLINE
				PROPERTY LINE
				LOT LINE
				SECTION LINE
				SECTION CORNER
				RIGHT-OF-WAY LINE
				EASEMENT LINE
				FENCE
				SANITARY SEWER MAIN
				SANITARY SEWER MANHOLE
				SANITARY SEWER CLEAN OUT
				CULINARY WATER LINE
				PRESSURIZED IRRIGATION
				GRAVITY IRRIGATION
				TEE
				GATE VALVE
				BEND (ANGLE NOTED)
				STUB / CAP
				HYDRANT
				WATER METER
				WATER MANHOLE
				SECONDARY WATER SERVICE/VALVE
				GRAVITY IRRIGATION MANHOLE
				GRAVITY IRRIGATION BOX
				STORM DRAIN PIPE
				CULVERT WITH FLARED END SECTION
				STORM DRAIN MANHOLE
				STORM DRAIN COMBO BOX
				STORM DRAIN CURB INLET
				JUNCTION STRUCTURE
				BURIED ELECTRIC LINE
				OVERHEAD ELECTRIC LINE
				ABANDONED COMM. LINE

LEGEND (cont.)		EXISTING	PROPOSED	
				BURIED FIBER OPTIC LINE
				ABANDONED GAS LINE
				GAS LINE
				GAS VALVE / GAS METER
				BURIED TELEPHONE
				POWER POLE
				GUY WIRE ANCHOR
				ELECTRICAL EQUIPMENT
				ELECTRICAL TRANSFORMER
				FIBER OPTIC PEDESTAL
				GRADE TO DRAIN
				EXTENTS OF GRADING
				TELEPHONE PEDESTAL
				HANDHOLE BOX
				STREET LIGHT
				SIGN (SINGLE POLE, 2 OR MORE POLES)
				MAILBOX
				ASPHALT PAVEMENT
				CONCRETE FLATWORK
				UNTREATED BASE COURSE
				LANDSCAPE
				RIP-RAP
				SPOT ELEVATION
				SECTION / DETAIL CALL-OUT SYMBOL
				EXISTING SHRUB
				EXISTING TREE
				OVERHEAD COMM. LINE
				UNDERGROUND COMM. LINE
				OVERHEAD CABLE TV
				BURIED CABLE TV

90% BID SET
NOT FOR CONSTRUCTION

REVISION

NO.	DESCRIPTION	BY	DATE

LEGEND & ABBREVIATIONS

6400 SOUTH BRIDGE REPLACEMENT
UTAH COUNTY NEAR BENJAMIN, UTAH

PROJ. #: FF 24060.01
DATE: JUNE, 2024
DESIGN BY: TPB
CHECKED BY: JGJ

SHEET
GN02

3 OF 8

3160 W. Clubhouse Drive, Ste. A
Lehi, UT 84043
801.768.7200

PLOT: 2024-06-04 02:27 PM
 PATH: \\UTAH\BROJECTS\ACTIVE\2024\IF 24060.01 - 6400 SOUTH BENJAMIN'S SLOUGH BRIDGE REPLACEMENT\700 - CAD\SHEET FILES\DWG

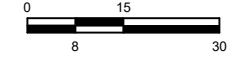
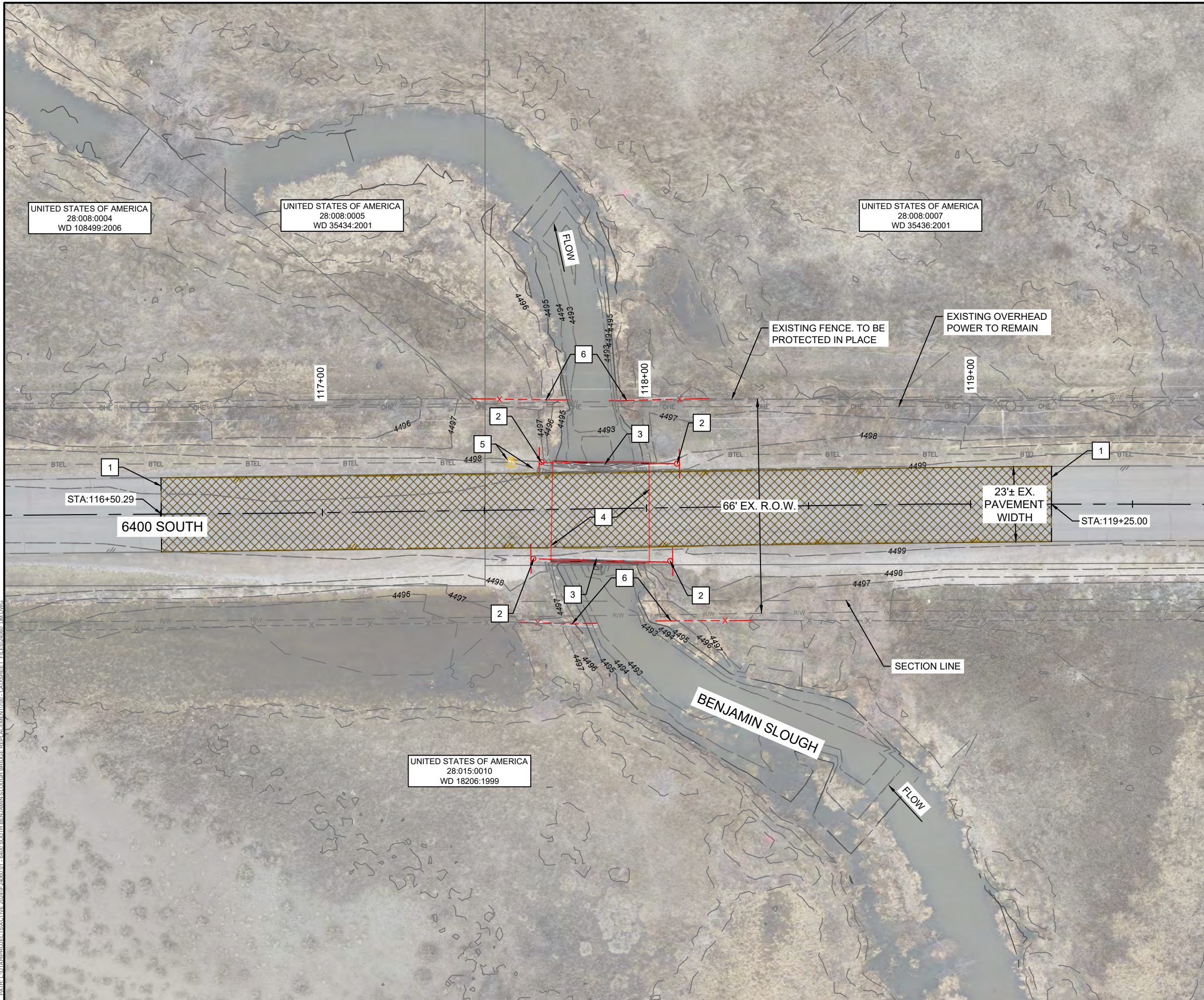

SCALE: 1" = 30'
 (SCALE ONLY VALID FOR 11" x 17" PAPER)

LEGEND

FULL DEPTH ASPHALT PAVEMENT SECTION

KEYNOTES

- 1 SAWCUT EXISTING ASPHALT (FULL DEPTH)
- 2 REMOVE EXISTING SIGN
- 3 REMOVE EXISTING GUARDRAIL
- 4 REMOVE EXISTING BRIDGE STRUCTURE
- 5 EXISTING COMM. PEDESTAL AND BURIED COMM. LINE TO BE RELOCATED BY LUMEN. COORDINATE AND SCHEDULE WORK WITH LUMEN.
- 6 REMOVE EXISTING FENCE



90% BID SET NOT FOR CONSTRUCTION	
REVISION	BY / AFR / DATE

DEMOLITION PLAN

6400 SOUTH BRIDGE REPLACEMENT
 UTAH COUNTY NEAR BENJAMIN, UTAH

PROJ. #: IF 24060.01
DATE: JUNE, 2024
DESIGN BY: TPB
CHECKED BY: JGJ
SHEET
DM01
4 OF 8

PLOT: 2024-06-04 02:29 PM
 PATH: \\UTAH\DESIGN\ACTIVE\2024\IF 240601 - 6400 SOUTH BENJAMIN'S LOUGH BRIDGE REPLACEMENT - CAD\SSHEET_FILES\240601_TC.DWG

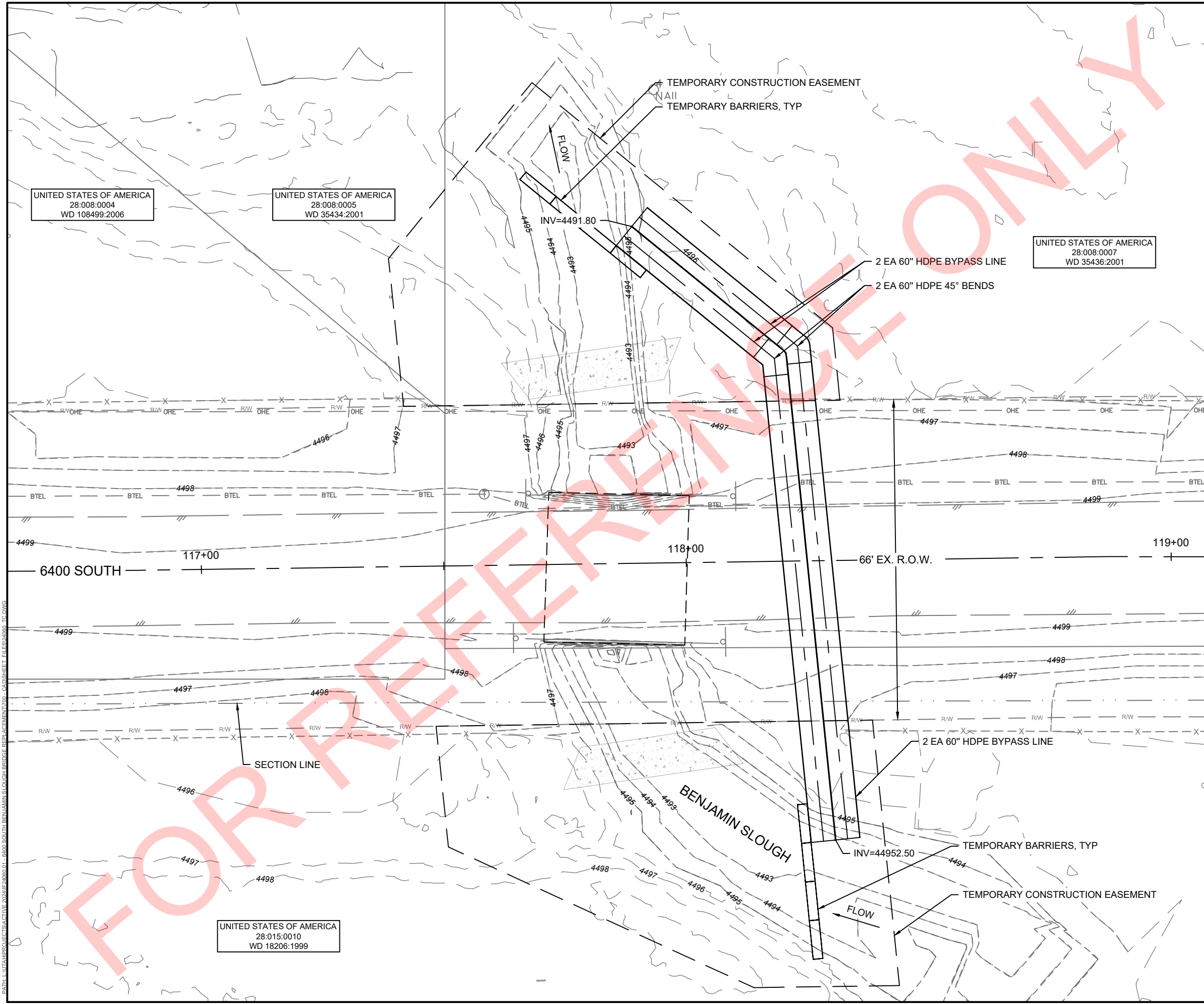

UNITED STATES OF AMERICA
 28:008:0004
 WD 108499:2006

UNITED STATES OF AMERICA
 28:008:0005
 WD 35434:2001

UNITED STATES OF AMERICA
 28:008:0007
 WD 35436:2001

UNITED STATES OF AMERICA
 28:015:0010
 WD 18206:1999

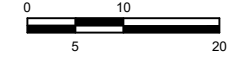

SCALE: 1" = 20'
 (SCALE ONLY VALID FOR 11" x 17" PAPER)

LEGEND

EXISTING ASPHALT

CivilScience
 3160 W. Clubhouse Drive, Ste. A
 Lehi, UT 84043
 801.768.7200

90% BID SET
 NOT FOR CONSTRUCTION

NO.	REVISION	DESCRIPTION	BY	DATE

TEMPORARY CONSTRUCTION STAGING PLAN
 6400 SOUTH BRIDGE REPLACEMENT
 UTAH COUNTY NEAR BENJAMIN, UTAH

PROJ. #: IF 24060.01
DATE: JUNE, 2024
DESIGN BY: TPB
CHECKED BY: JGJ
SHEET
TC01
5 OF 8

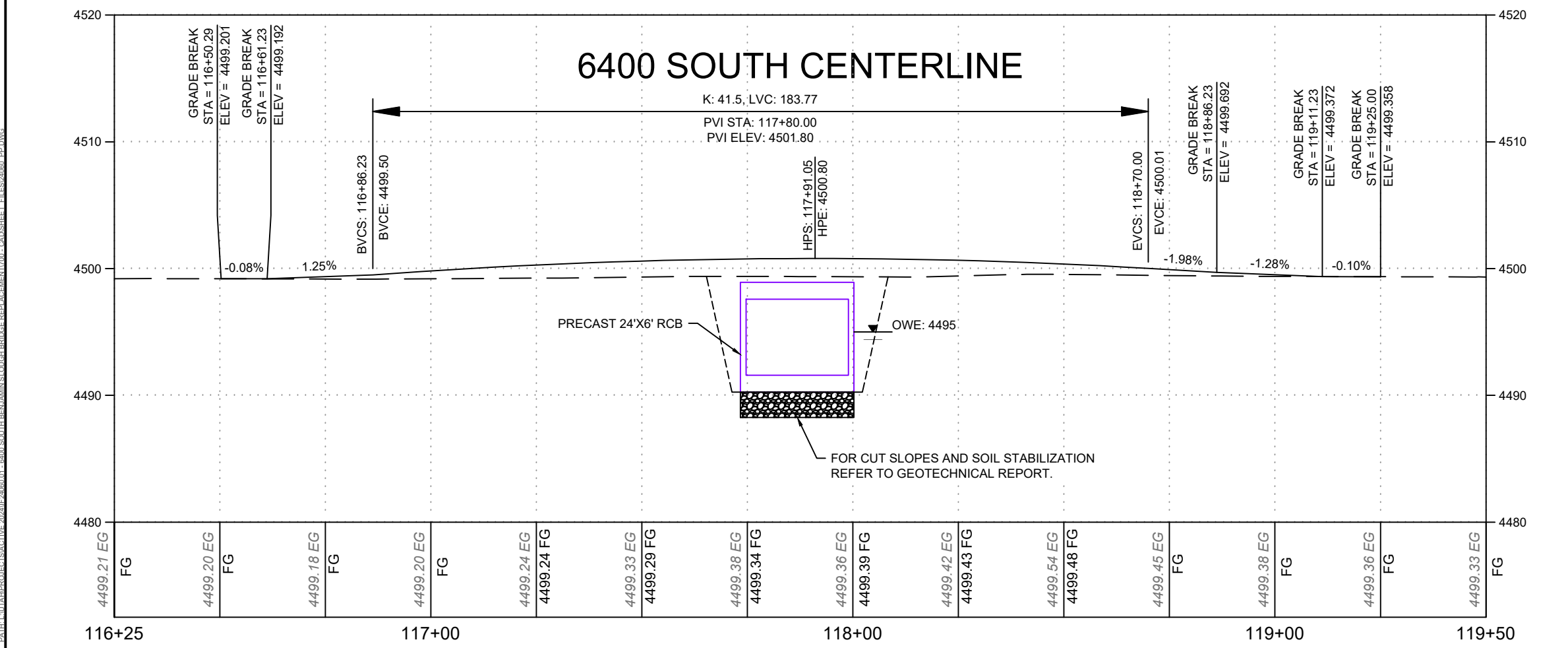
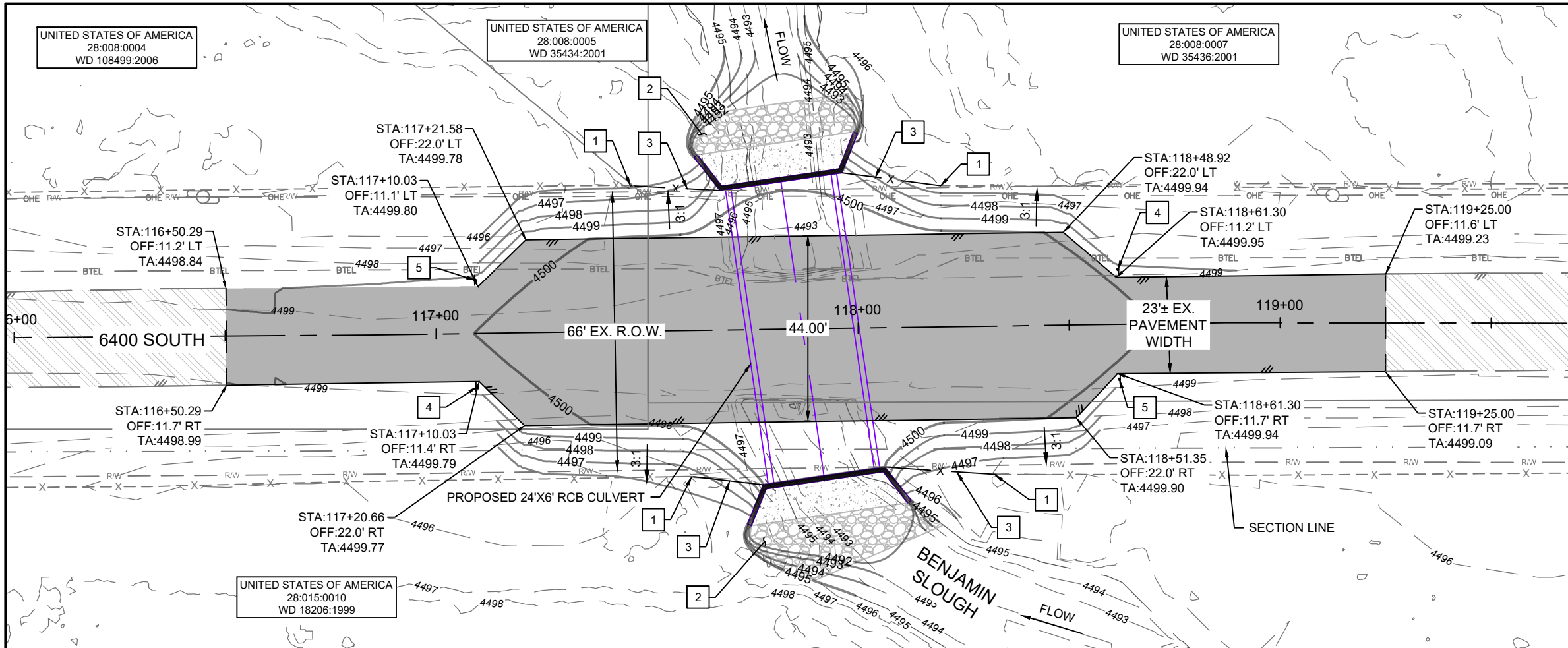

811
Know what's below.
Call before you dig.

0 15 30
8
SCALE: 1" = 30'
(SCALE ONLY VALID FOR 11" x 17" PAPER)

LEGEND

- FULL DEPTH ASPHALT PAVEMENT SECTION (SEE SHEET ST01)
- EXISTING ASPHALT
- CONCRETE APRON (6-INCH SLAB WITH #4 BAR ON CENTER EACH WAY)

KEYNOTES

- CONSTRUCT PUBLIC ACCESS POINT (SEE DETAIL BELOW)
- FURNISH AND INSTALL D50=12" RIP RAP.
- CONSTRUCT FIELD FENCE TO HEAD WALL
- FURNISH AND INSTALL OM-3R AND R12-1 SIGN PER M.U.T.C.D.
- FURNISH AND INSTALL OM-3L PER M.U.T.C.D.

PLAN & PROFILE

6400 SOUTH BRIDGE REPLACEMENT
UTAH COUNTY NEAR BENJAMIN, UTAH

TOP VIEW

SIDE VIEW

PUBLIC ACCESS POINT

PP01

6 OF 8

90% BID SET
NOT FOR CONSTRUCTION

NO.	DESCRIPTION	BY	DATE

PROJ. #: IF 24060.01
DATE: JUNE, 2024
DESIGN BY: TPB
CHECKED BY: JGJ
SHEET

PLOT: 2024-06-04 02:31 PM
 PATH: I:\UTAH\PROJECTS\ACTIVE\2024\IF\24060.01 - 6400 SOUTH BRIDGE REPLACEMENT\700 - CAD\SHEET_FILES\24060.01.DWG

CivilScience

3160 W. Clubhouse Drive, Ste. A
Lehi, UT 84043
801.768.7200



SCALE: 1" = 10'

(SCALE ONLY VALID FOR 11" x 17" PAPER)

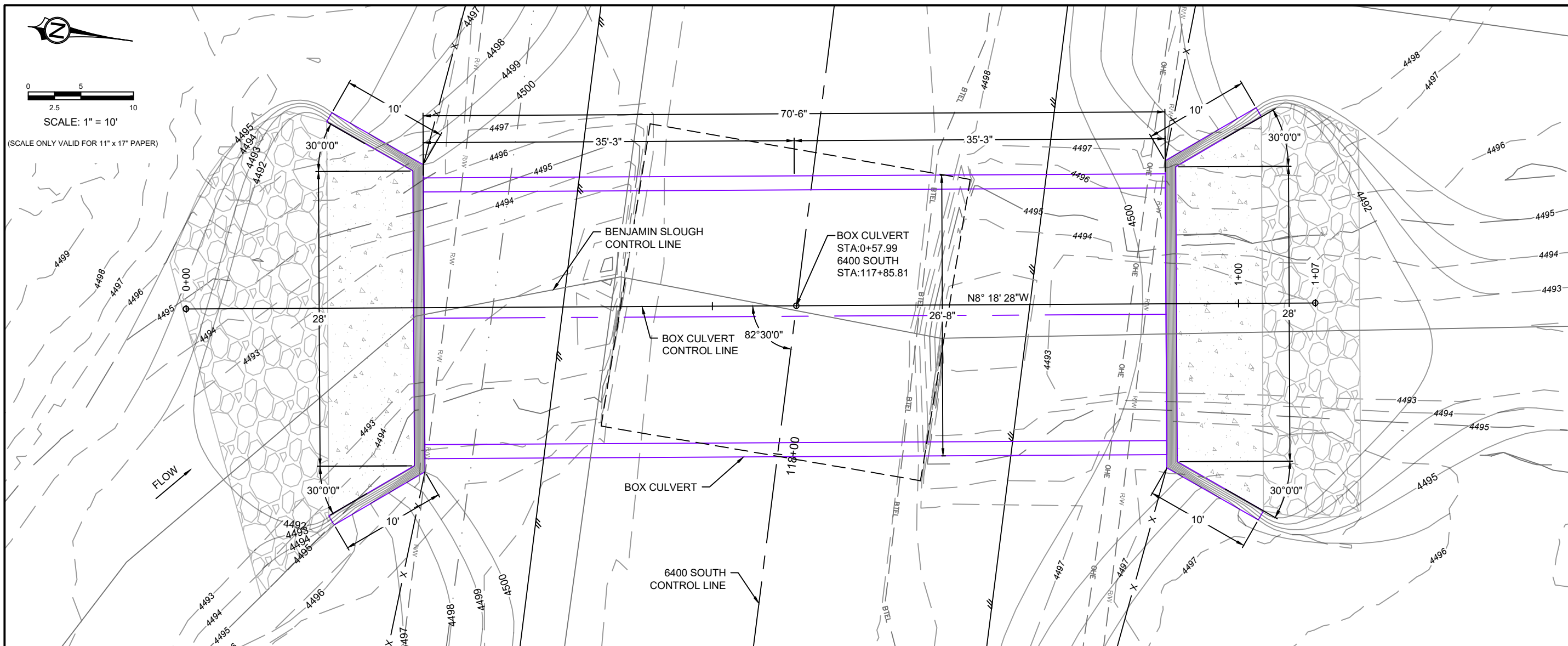

PLAN

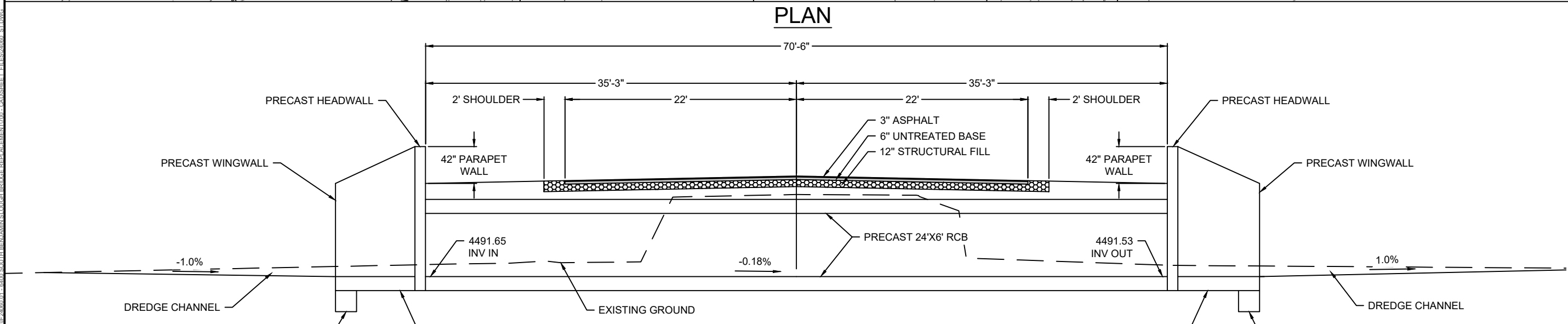

PROFILE



3160 W. Clubhouse Drive, Ste. A
Lehi, UT 84043
801.768.7200

90% BID SET
NOT FOR CONSTRUCTION

NO.	REVISION	DESCRIPTION	DATE

PRECAST RCB SITUATION AND LAYOUT

6400 SOUTH BRIDGE REPLACEMENT
UTAH COUNTY NEAR BENJAMIN, UTAH

PROJ. #: IF 24060.01
DATE: JUNE, 2024
DESIGN BY: TPB
CHECKED BY: JGJ

SHEET

ST01

7 OF 8

PLOT: 2024-06-04 02:33 PM
PATH: \\UTAH\DESIGN\ACTIVE\2024\IF\24060.01 - 6400 SOUTH BENJAMIN SLOUGH BRIDGE REPLACEMENT\10 - CAD\SHEET_FILES\24060 - ST.DWG

PLOT: 2024-06-04 02:33 PM
 PATH: \\UTAHREG\PROJECTS\ACTIVE\2024\IF\240601-6400 SOUTH BENJAMIN SLOUGH BRIDGE REPLACEMENT\700 - CAD\SHRHEET_FILES\240601-ST.DWG

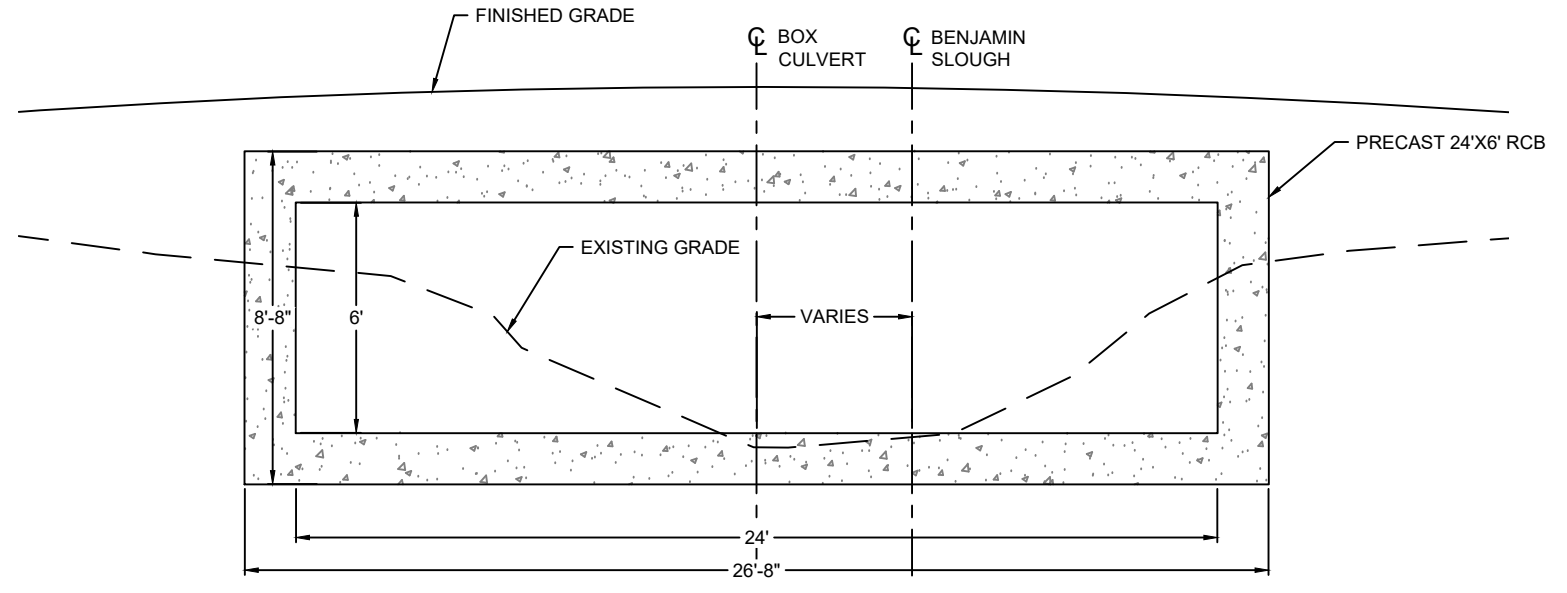

TYPICAL SECTION

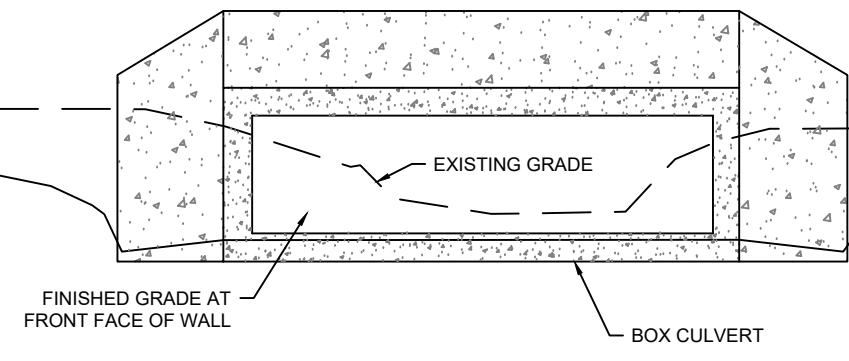

NORTH WINGWALL ELEVATION

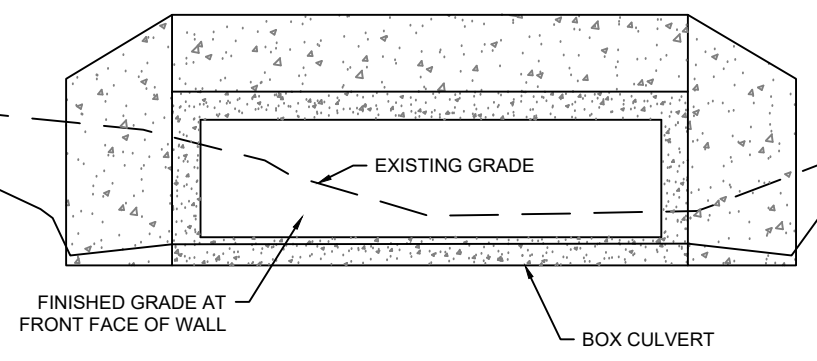

SOUTH WINGWALL ELEVATION

**90% BID SET
NOT FOR CONSTRUCTION**

NO.	REVISION	DESCRIPTION	BY	DATE

PRECAST RCB SITUATION AND LAYOUT
 6400 SOUTH BRIDGE REPLACEMENT
 UTAH COUNTY NEAR BENJAMIN, UTAH

EXHIBIT A

CONTRACTOR INFORMATION FORM

In order to receive consideration, submitted bids must contain responses to all questions.
Failure to respond to all questions may result in disqualification of the bid.

COMPANY NAME & ADDRESS: _____

Is this an Office: _____, Home: _____, Shop: _____, Other: _____
Telephone Number: (____) _____, Emergency Number: (____) _____.
Answering Machine: (____) _____, Fax Number: (____) _____.

COMPANY OWNER: _____
COMPANY PRESIDENT: _____
CONTACT PERSON: _____ Phone: _____
EMAIL ADDRESS: _____

Type of Company (Partnership, Corporation, Venture etc.): _____

If a Corporation, in what State Incorporated: _____
Business License Number: _____
State of Utah Contractor License Number: _____
Federal Tax Identification Number: _____
D&B D-U-N-S Number: _____
How long has this company been in business: _____ Years, and _____ Months.

Officers authorized to execute contracts: _____

What would happen to your company in the event of the owner's absence or death?

Brief History of the Company: _____

Are there any judgments, suits or claims pending against your company? If Yes, attach a written explanation. **YES NO**

Has your company operated under any other name (s)? If Yes, attach a written explanation. **YES NO**

CONTRACTOR INFORMATION FORM Page 2

Has your firm failed to complete a contract within the last five years?
If "yes" attach explanation. **YES NO**

Has your firm or any partner or officers ever been involved in any
bankruptcy action? If "yes" attach explanation. **YES NO**

Has your firm ever been listed on the Excluded Parties List System? **YES NO**

Are any of your firm's owners, officers, employees, or agents also
employees of Utah County or related to any employees of Utah County
If "yes" attach explanation. **YES NO**

FINANCIAL REFERENCES

1. Bank Name & Address _____

Manager _____ Phone _____

2. Bank Name & Address _____

Manager _____ Phone _____

CLIENT REFERENCES

1. Name: _____, Contact: _____
Address: _____, Phone: _____

2. Name: _____, Contact: _____
Address: _____, Phone: _____

3. Name: _____, Contact: _____
Address: _____, Phone: _____

4. Name: _____, Contact: _____
Address: _____, Phone: _____

EXHIBIT B

CERTIFICATE OF NON-COLLUSION

STATE OF UTAH) Invitation to Bid
)SS for
COUNTY OF UTAH) 6400 South Bridge Replacement – Culvert Purchase

AFFIDAVIT

The undersigned of lawful age, being first duly sworn, disposes and says:
That as a condition precedent to the award of the Utah County project as above captioned,

I _____
 (owner, partner, officer or delegate)

of _____ do
 (company)

solemnly swear that neither I, nor to the best of my knowledge any member or members of my firm or company have either directly or indirectly restrained free and competitive bidding on this project by entering into any agreement, participating in any collusion, or otherwise taking any action unauthorized by Utah County, with regard to this bid or potential agreement resulting therefrom.

Contractor Signature

By: _____
Title: _____

Subscribed/sworn to before me this ____ day of _____ 2024 A.D.
My Commission Expires _____
Residing at _____

Seal

By: _____ Notary Public

EXHIBIT C

SAMPLE AGREEMENT WITH STANDARD TERMS & CONDITIONS



AGREEMENT

THIS AGREEMENT is made and entered into by and between Utah County, a political and corporate body of the State of Utah, located at 100 East Center Street, Provo, Utah 84606, and the following CONTRACTOR:

Name: _____ Contact Person: _____

Address: _____ Phone #: _____

City: _____ State: _____ Zipcode: _____ Email: _____

Legal Status of Contractor: [] Sole Proprietor [] Non-Profit Corporation Limited Liability Company (LLC)
[] Partnership [] For-Profit Corporation
[] Government Department: _____

1. PURPOSE OF CONTRACT

This agreement is to obtain the following products, services, or products and services (be specific):

2. CONTRACT COSTS

Contractor will be:

- [] paid a maximum of \$_____ for costs authorized by this agreement;
[] compensated in accordance with ATTACHMENT B: CONTRACTOR's Proposal.

3. CONTRACT PERIOD

The term of this agreement shall commence on: [] _____, or [] the date of execution of this agreement. This agreement shall terminate on _____ unless terminated early or performance has been completed.

4. ATTACHMENTS

The following indicated attachments are fully incorporated into this agreement:

- [] A: Utah County Standard Terms and Conditions [] F: _____
[] B: CONTRACTOR's Proposal [] G: _____
[] C: Special Provisions [] H: _____
[] D: Utah County Procurement Compliance
[] E: General Liability and Workers Compensation Certificate

Except as explicitly modified by ATTACHMENT C: Special Provisions, any ambiguities or conflicting terms will be resolved by granting deference to the terms of ATTACHMENT A: Utah County's Standard Terms and Conditions.

IN WITNESS WHEREOF, the parties have executed this agreement on ____ of _____ 20__.

ATTEST:
AARON R. DAVIDSON
Utah County Clerk

BOARD OF COUNTY COMMISSIONERS,
UTAH COUNTY, UTAH

By: _____
Deputy Clerk

By: _____
BRANDON B. GORDON, Chair

APPROVED AS TO FORM AND LEGALITY:
JEFFREY S. GRAY
Utah County Attorney

CONTRACTOR

By: _____
Deputy Utah County Attorney

By: _____
Its: _____

ATTACHMENT A:
UTAH COUNTY STANDARD TERMS AND CONDITIONS FOR PRODUCTS AND SERVICES

1. **DEFINITIONS.** The following terms shall have the meanings set forth below:
 - (A) The “Agreement” consists of the following documents:
 - (i) The Utah County Agreement cover page, which contains the signatures of Utah County and Contractor;
 - (ii) This Attachment A: Utah County Standard Terms and Conditions for Products and Services; and
 - (iii) Any other express written attachments that are incorporated by reference on the Utah County Agreement cover page.
 - (B) “Contractor” means the individual or entity delivering the Products and Services identified in the Agreement. The term “Contractor” shall include the individual’s or entities’ agents, officers, employees, and partners.
 - (C) The “County” means Utah County, a political subdivision of the State of Utah, as directed and managed by a majority vote of the Board of County Commissioners of Utah County.
 - (D) “Products” means any products to be delivered to the County by Contractor as described in the Utah County Agreement cover page, including any products described in any attachments that are incorporated by reference on the Utah County Agreement cover page.
 - (E) “Services” means any services to be performed for the County by Contractor as described in the Utah County Agreement cover page, including any services described in any attachments that are incorporated by reference on the Utah County Agreement cover page.
 - (F) “Subcontractors” mean subcontractors or subconsultants that are under the direct or indirect control or responsibility of Contractor, and includes all independent contractors, agents, employees, or authorized resellers.
2. **EXTRA WORK.**
 - (A) Extra work shall be undertaken only when previously authorized in writing by the County and is defined as additional work which is neither shown nor defined in the Agreement or the attached Contractor’s proposal (if any) but determined by the County to be necessary to the project. Extra work is also defined as that additional effort necessary by reason of changed conditions which are radical and unforeseeable.
 - (B) Miscellaneous items normally associated with the major work items included in the Agreement, but which may not be specifically identified, shall be furnished by Contractor as if they had been included in the Agreement, without additional cost to the County. After written prior authorization of the Board of County Commissioners of Utah County, payment for authorized extra work will be made in the previously authorized amount only.
3. **PAYMENT.** Payments from the County are normally made within thirty (30) days following the date an order is delivered, service is performed, or the date a correct invoice is received, whichever is later. All payments for the Agreement will be remitted electronically, by mail, or as otherwise determined by the County. Contractor shall accept payment by check or by Purchasing Card without any additional fees.
4. **OWNERSHIP IN INTELLECTUAL PROPERTY.** The County and Contractor each recognize that each has no right, title, interest, proprietary or otherwise in the intellectual property owned or licensed by the other, unless otherwise agreed upon by the parties in writing. The County will have all rights, title, and

ownership of all websites and social media accounts, including any passwords, usernames, or other pertinent login information or hosting credentials; advertising materials, including any content or work product; images; newsletters; and intellectual property, including derivative works, created, or arising out of the performance of the Agreement, unless otherwise indicated in the Agreement. Contractor will give the County a list of all current passwords, usernames, and any other relevant information or credentials necessary for access and control of any property under the Agreement upon completion of the Agreement or upon the County's request.

5. INSURANCE.

(A) Contractor agrees to carry Commercial General Liability insurance coverage equal to or greater than three million dollars (\$3,000,000) per occurrence, or in a lesser amount if explicitly authorized and identified on the Utah County Agreement cover page. This coverage shall provide liability insurance to cover the activities of Contractor and its subcontractors, all equipment and vehicles, public or private, used in the performance of the Agreement, and to add the County as an additional insured for any Services in the contract. Prior to commencement of work, Contractor shall furnish a Certificate of Insurance to the County evidencing that Contractor has this insurance in place and that the County is an additional insured. An umbrella policy may be used to supplement the Commercial General Liability insurance coverage if needed to reach the coverage requirement.

(B) Prior to commencement of Services, Contractor shall furnish a Certificate of Insurance to the County evidencing that Contractor has Workers Compensation Insurance for the Contractor and Subcontractors.

6. Data Privacy. If Contractor, as part of this agreement or transaction, will receive or work with County information, or if they will be gathering data on behalf of the County, Contractor will be required to comply with the following provisions as applicable.

(A) **Cyber Insurance.** Contractor agrees to purchase and maintain throughout the term of this Agreement a technology and professional liability insurance policy, including coverage for network security and data protection liability insurance (also called "cyber liability") covering liabilities for financial loss resulting or arising from acts, errors, or omissions, in rendering technology or professional services or in connection with the specific services described in violation or infringement of any right of privacy, including breach of security and breach of security or privacy laws, rules or regulations globally, now or hereinafter constituted or amended; data theft, damage, unauthorized disclosure, destruction, or corruption, including without limitation, unauthorized access, unauthorized use, identity theft, theft of personally identifiable information or confidential government, corporate, or public information in whatever form; transmission of a computer virus or other type of malicious code; participation in a denial of service attack on third party computer systems; loss or denial of service; with no cyber terrorism exclusion; with a minimum limit of three million dollars (\$3,000,000) for each and every claim and in the aggregate. Such coverage must include technology and professional liability including breach of contract, privacy and security liability, privacy regulatory defense and payment of civil fines, payment of credit card provider penalties, and breach response costs (including without limitation, notification costs, forensics, credit protection services, call center services, identity theft protection services, and crisis management and public relations services). Such insurance must explicitly address all of the foregoing without limitation if caused by an employee of the Contractor or an independent contractor working on behalf of the Contractor in performing services under this Agreement. Policy must provide coverage for wrongful acts, claims, and lawsuits anywhere in the world. Such insurance must include affirmative contractual liability coverage for any data breach indemnity in this Agreement, for all damages, defense costs, privacy regulatory civil fines and penalties, and reasonable and necessary data breach notification, forensics, credit protection services, public relations and crisis management, and other data breach mitigation services resulting from a confidentiality or security breach by or on behalf of the Contractor. Contractor shall furnish evidence of coverage at the time of any bid or proposal, and upon request at any time during the term of the Agreement.

(B) Protecting Personal Identifying Information. Utah Code 63A-19-101 *et seq.* requires governmental agencies follow specific standards to protect personal data privacy. Consistent with Utah Code 63A-19-401(4)(a) Contractor acknowledges that Contractor is also required to comply with the relevant requirements of this chapter with regard to the personal data processed or accessed by Contractor as part of Contractor's duties under the Agreement to the same extent as required of the governmental entity.

7. **GOVERNING LAW AND VENUE.** The Agreement shall be governed, construed, and enforced in accordance with the laws of the State of Utah and Utah County. Any action or proceeding arising from the Agreement shall be brought in a court of competent jurisdiction in the State of Utah. Venue shall be in Provo, in the Fourth Judicial District Court for Utah County.
8. **COMPLIANCE WITH LAWS AND REGULATIONS.** At all times during the Agreement, Contractor and all Products and Services performed under the Agreement shall comply with all applicable federal and state constitutions, laws, rules, codes, orders, and regulations, including applicable licensure and certification requirements. Any violation by Contractor of applicable law shall constitute an event of default under the Agreement and Contractor shall indemnify the County from and against any and all liability arising out of or connected with the violation, to include all attorney fees and costs incurred by the County as a result of the violation. Contractor is responsible, at its expense, to acquire, maintain, and renew all necessary permits and licenses required for its lawful performance of its duties and obligations under the Agreement during the term of the Agreement. To the extent that Contractor uses, stores, transfers, or manipulates any data in the performance of its obligations, Contractor will further comply with all applicable privacy and data laws and regulations, including but not limited to General Data Protection Regulation 2016/679 of the European Union ("GDPR") and similar provisions from any jurisdiction in the United States and any locations where data is or may be stored.
9. **EMPLOYMENT STATUS VERIFICATION.** Contractor shall register and participate in the Status Verification System and comply with Utah Code section 63G-12-302 of the Identity Documents and Verification Act. Contractor shall require an affidavit verifying compliance with Utah Code section 63-G-12-302 from each of its contractors and subcontractors.
10. **INDEPENDENT CONTRACTOR.** Contractor's legal status is that of an independent contractor, and in no manner shall Contractor be deemed an employee or agent of the County, and therefore is not entitled to any of the benefits associated with such employment. As an independent contractor, Contractor shall have no express or implied authority to bind the County to any agreements, settlements, liabilities, or understandings whatsoever, and agrees not to perform any acts as an agent for the County. Contractor shall remain responsible for all applicable federal, state, and local taxes, and all FICA contributions.
11. **INDEMNIFICATION.** To the fullest extent permitted by law, Contractor shall indemnify, defend, and hold harmless the County, its officers, employees, and agents, from and against any and all claims, demands, causes of action, orders, decrees, judgements, losses, risks of loss, damages, expenses, and liabilities arising out of or related to the Agreement. Contractor shall also pay any litigation expenses that the County incurs, including attorney's fees, arising out of or related to the Agreement. As between the parties to the Agreement, Contractor shall assume sole liability for any injuries or damages caused to a third party as a result of fulfillment of the Agreement. The County reserves the right to conduct, control, and direct its own defense for any claims, demands, causes of action, orders, decrees, judgements, losses, damages, expenses, and liabilities arising out of or related to the Agreement.
12. **INDEMNIFICATION RELATING TO INTELLECTUAL PROPERTY.** Contractor shall indemnify and hold the County harmless from and against any and all damages, expenses (including reasonable attorney's fees), claims, judgments, liabilities, and costs in any action or claim brought against the County for infringement of a third party's copyright, trademark, trade secret, or other proprietary right arising from this Agreement.

13. **GOVERNMENTAL IMMUNITY.** The County is a corporate and political subdivision of the State of Utah, subject to the Governmental Immunity Act of Utah (the “Act”). The County does not waive any procedural or substantive defense or benefit provided or to be provided by the Act or any comparable legislative enactment. The parties agree that the County shall only be liable within the parameters of the Act. Nothing contained in the Agreement shall be construed in any way to modify the limits set forth in that Act or the basis for liability as established in the Act.
14. **NON-FUNDING CLAUSE.** The County intends to request the appropriation of funds to be paid for the services provided by Contractor under the Agreement. The Agreement shall create no obligation on the County as to succeeding annual budget cycles and if funds are not available beyond December 31 of any effective annual budget cycle of the Agreement, or if the budget is amended and such funds are no longer available, the County’s obligation for performance of the Agreement shall be null and void. This termination shall not be construed as a breach of the Agreement or any event of default under the Agreement and the termination shall be without penalty, and no right of action for damages or other relief shall accrue to the benefit of Contractor, its successors, or its assigns, as to the Agreement. If funds are not appropriated for a succeeding annual budget cycle to fund performance by the County under the Agreement, or if the budget is amended to make such funds no longer available, the County shall attempt to notify Contractor of non-funding and the termination of the Agreement.
15. **SALES TAX EXEMPTION.** The County’s sales and use tax exemption number is 11748944 002 STC. The tangible personal property or services being purchased are to be paid from the County’s funds and used in the exercise of that entity’s essential functions. If the items being purchased are construction materials, they will be converted into real property by employees of this government entity, unless otherwise stated in the Agreement. As such, Contractor shall not charge the County any sales tax for the product(s) purchased under the Agreement.
16. **CONFIDENTIALITY.** Materials, information, data, reports, plans, analyses, budgets, and similar documentation provided to or prepared by Contractor in performance of the Agreement shall be owned by the County and shall be held confidential by Contractor. In addition, all information provided to Contractor by the County for the purposes of Contractor’s performance of the Products or Services, whether provided in writing or any other form, shall be held in confidence by Contractor and Contractor shall not release any of the information to any third party, any member of Contractor’s firm who is not involved in the performance of Products or Services, or to any representative of the news media without prior written consent of the County. The County shall have the sole obligation or privilege of releasing such information as required by law. Any employee or member of Contractor’s firm, subcontractor, or agent with whom Contractor shares any information as described in this section will be under the same obligations of confidentiality, and Contractor is required to secure and provide to County written commitments to that effect from each such recipient of information.
17. **TERMINATION.** Unless otherwise stated in Attachment C: Special Provisions, the Agreement may be terminated with cause by either party, in advance of the specified termination date, upon written notice being given by the other party. If the violation is reasonably subject to cure, the party in violation will be given 10 working days after notification to correct and cease the violation, after which the Agreement may be terminated for cause. Time allowed for cure will not diminish or eliminate Contractor’s liability for damages. The Agreement may be terminated without cause, in advance of the specified expiration date, by the County upon 30 days prior written notice being given to Contractor. On termination of the Agreement, all accounts and payments will be processed according to the financial arrangements in the Agreement for approved services rendered prior to the date of termination, subject to any offsetting claims by the County.
18. **FORCE MAJEURE.** The County will not be held liable for delay or default caused by fire, riot, acts of God, State or Utah County declared state of emergency, or war. The County may terminate the Agreement after determining such delay or default will reasonably prevent successful performance of the Agreement.
19. **SEVERABILITY OF AGREEMENT.** The invalidity of any portion of the Agreement shall not prevent

the remainder from being carried into effect.

20. **LEGAL SUPPORT.** Contractor shall be responsible to provide all legal support for the project including but not limited to the preparation of contracts with subcontractors.
21. **NO PRESUMPTION.** Should any provision of the Agreement require judicial interpretation, the Court interpreting or construing the same shall not apply a presumption that the terms in the Agreement shall be more strictly construed against the party, by reason of the rule of construction that a document is to be construed more strictly against the person who himself or through his agents prepared the same, it being acknowledged that all parties have participated in the preparation hereof.
22. **WARRANTY.** To the maximum extent permitted under Utah State law, Contractor warrants to the County that all services and materials furnished under the Agreement will be of the highest quality, consistent with the degree of skill and care ordinarily exercised by similarly situated members of Contractor's profession, and in conformance with the terms hereof.

Contractor warrants and assumes responsibility for all products (including hardware, firmware, and software products) that it licenses, contracts, or sells to the County under the Agreement for a period of one year, unless otherwise specified and mutually agreed upon elsewhere in the Agreement or Contractor's proposal, attached hereto (if any). Contractor (seller) acknowledges that all warranties granted to the buyer by the Uniform Commercial Code of the State of Utah apply to the Agreement. Product liability disclaimers and warranty disclaimers from the seller are not applicable to the Agreement unless otherwise specified and mutually agreed upon elsewhere in the Agreement. In general, Contractor warrants that: (1) the product will do what the salesperson said it would do, (2) the product will live up to all specific claims that the manufacturer makes in their advertisements, (3) the product will be suitable for the ordinary purposes for which such product is used, (4) the product will be suitable for any special purposes that the County has relied upon Contractor's skill or judgment to consider when it advised the County about the product, (5) the product has been properly designed and manufactured, and (6) the product is free of defects or unusual problems about which the County has not been warned in writing prior to entering into the Agreement. Remedies available to the County include, without limitation, the following: Contractor will repair or replace (at no charge to the County) the product whose nonconformance is discovered and made known to Contractor in writing. If the repaired or replaced product proves to be inadequate, or fails of its essential purpose, Contractor will refund the full amount of any payments that have been made. Nothing in this warranty will be construed to limit any rights or remedies the County may otherwise have under the Agreement.

23. **TIME IS OF THE ESSENCE.** The County and Contractor recognize that time is of the essence here and the County will suffer financial loss if any Products or Services are not delivered and performed within the time specified in the Agreement, plus any extensions approved in writing by the County. Contractor shall be liable for all reasonable damages to the County and to anyone whom the County may be liable to as a result of Contractor's failure to timely deliver and perform the Products and Services.
24. **DELIVERY.** Unless otherwise specified in this contract, all deliveries will be F.O.B. destination with all transportation and handling charges paid by Contractor. Responsibility and liability for loss or damage will remain with Contractor until final inspection and acceptance when responsibility will pass to the County except as to latent defects, fraud, and Contractor's warranty obligations, if applicable.
25. **CONDITION AND TITLE.** The products delivered by Contractor to the County shall be new and free of all faults and defects. Upon payment of the purchase price by the County to Contractor, Contractor shall provide the County with clear title, free and clear of all liens and encumbrances, if applicable.
26. **INTERPRETATION OF AGREEMENT.** Whenever the context of any provision shall require it, the singular number shall be held to include the plural number, and vice versa, and the use of any gender shall include all genders. The paragraph and section headings in this Agreement are for convenience only and do

not constitute a part of the provisions hereof.

27. **NOTICES.** All notices, demands and other communications required or permitted to be given hereunder shall be in writing and shall be deemed to have been properly given if delivered by hand or by certified mail, return receipt requested, postage paid, to the parties at their respective places of business, or at such other addresses as may be designated by notice given hereunder, including by email to the contact person for Contractor at the email address identified on the Utah County Agreement cover page.
28. **COUNTERPARTS AND FACSIMILE SIGNATURES.** The Agreement may be executed in counterparts, each of which when executed and delivered shall be deemed to be an original, binding between the executing parties, and all of which together constitute one and the same instrument. Original, facsimile, emailed, texted, electronic, or power of attorney signatures shall be binding upon the executing party.
29. **AMENDMENTS.** No oral modifications or amendments to the Agreement shall be effective. The Agreement may be modified or amended by a written agreement signed by the parties.
30. **ASSIGNMENT.** The parties to the Agreement shall not assign the Agreement without the prior written consent of the other party to the Agreement. No assignment shall relieve the original parties from any liability arising out of or related to the Agreement.
31. **SUCCESSORS IN INTEREST.** The Agreement shall be binding upon the heirs, successors, administrators, and assigns of each of the parties.
32. **WAIVER.** A waiver of any right, power, or privilege shall not be construed as a waiver of any subsequent right, power, or privilege. Any waiver must be in writing and signed by the party making the waiver.
33. **SURVIVAL.** The provisions of this Agreement which by their terms call for performance subsequent to termination of the Agreement shall so survive such expiration or termination, such as but not limited to: **Section 4. Ownership of Intellectual Property, Section 11. Indemnification, Section 12. Indemnification Relating to Intellectual Property, and Section 16. Confidentiality.**
34. **ENTIRE AGREEMENT.** The Agreement shall constitute the entire agreement between the parties and any prior understanding or representation of any kind preceding the date of the Agreement shall not be binding upon either party except to the extent incorporated in the Agreement.

Revised June 11, 2024